

No. of RPM:

(based on the used device and not on the type of machining)

Poliangular attachments for internal

Models	0100N	0200N	0500N	1100N	2100N	3100N	3100S	4100XS
RPM	2000			1500		1200		1000

Poliangular attachments for external

Models	0200E	5100E	7100E	8100E	9100E
RPM	2000	1500	1200		1000

Feeds (for internal profile - for external profile, halve the feeds)

Machining material	FEED per RPM					
	Hexagons		Squares		Torx	
	Up to mm. 14	Over mm. 14	Up to mm. 12	Over mm. 12	Up to T25	Over T27
Steel up to 700N/mm ² (AVP)	0,10	0,08	0,06	0,04	0,10	0,08
Steel from 700 to 900N/mm ² (C40)	0,08	0,06	0,05	0,03	0,08	0,06
Steel from 900 to 1200N/mm ² (K100)	0,05	0,03	0,03	0,02	0,05	0,03
Steel over 1200N/mm ² (K720)	0,03	0,02	0,02	0,02	0,03	0,02
Inox steel easy processing 1200N/mm ² (K720)	0,08	0,06	0,05	0,03	0,08	0,06
Inox steel difficult processing	0,05	0,03	0,03	0,02	0,05	0,03
Cast iron low hardness	0,10	0,08	0,06	0,04	0,10	0,08
Cast iron medium hardness	0,08	0,06	0,05	0,03	0,08	0,06
Cast iron high hardness	0,05	0,03	0,03	0,02	0,05	0,03
Aluminium with SI < 15%	0,15	0,10	0,10	0,08	0,15	0,12
Aluminium with SI > 15%	0,10	0,08	0,07	0,05	0,10	0,08
Brass	0,12	0,10	0,10	0,08	0,12	0,10
Bronze	0,10	0,08	0,07	0,05	0,10	0,08
Titanium	0,03	0,02	0,02	0,02	0,03	0,02

For **Hexagons**: It is recommended to create a pre-hole that is greater than the engraved diameter (approx 5%), if machining particularly hard materials or in the case of a hexagon larger than mm.14; if larger than mm.21, increase the pre-hole by 10%

For **Squares**: It is recommended to create a pre-hole that is greater than the engraved diameter (approx 10%), if machining particularly hard materials or in the case of a square larger than mm.12; if larger than mm.17, increase the pre-hole by 15%

Poliangolar is subjected to a series of controls to obtain the best centring to the device axis.

Based on the selected model, this **centring** is measured from the tool support surface **at mm.10 for 0100N, at mm. 15 for 0200N, a mm. 25 for models 1100N - 2100N – 3100N, at mm. 45 for model 3100S, at mm. 70 for model 4100XS and at mm. 100 or more for special Poliangulars**, and is within mm. 0.02-0.03. ●

The possible degree of precision is influenced by various elements, such as:

- 1) Precision of the machine tool and its components
- 2) Rigidity of the machine tool, as the machining force may generating vibrations or radial thrusts, and, for example, the drill spindle may bend and cause a misalignment
- 3) Perfect pre-hole axis-**Poliangular** device alignment in the case of working on pre-processed material

If broaching is done correctly, the polygonal slot will be identical in form and tolerance to the tool section.



When possible, it is **always recommended** to use the lever, provided with the **equipment**, as it effectively solves some problems during use.

In fact, it is used for :

- Positioning the tool in order to orient the sides or edge with regard to a particular reference;
- **Preventing, especially for deep slots,**

the tool and the slot itself from spinning due to the friction created during the process;

- Preventing the tool from being subjected to useless initial stress as, being inclined with regard to the cutting surface, there would be a surge in the machining, jeopardising both the machining itself as well as the finishing of the part and, as a result, the duration of the tool.

The provided lever may be replaced by any high resistance screw or any other suitable device and must be screwed into the threaded hole opposite of the tool blocking dowel.

It must be locked against a stop, or even better in a fork that is an integral part of the part carrying spindle in the case of a lathe machine, or in the case of perforating, drilling or milling machines, it will be fixed to the part clamping equipment.

In the case of a lathe, both will rotate and the Poliangolar body will remain stationary, whereas in the case of a milling or drilling machine, both will remain stationary and the Poliangolar body will rotate.



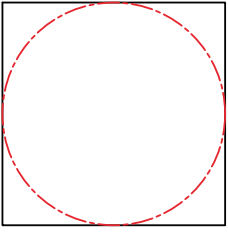

The machining pre-hole to make prior to broaching must have a diameter that is equal to or, better, slightly **larger** than the engraved circle of the desired section, including the tool tolerance in the case of an inner slot, whereas for an external slot the part must be turned a few tenths smaller than the edge dimension.

The measurement of the edges is: **“section” x 1.16 for hexagonal shapes and “section” x 1.41 for square shapes**. For square section slots, where the quantity of material to remove is considerable, the machining pre-hole must be made with a diameter that is approx. **10% greater** than the desired section. (example: square mm 14, pre-hole mm.15-15.5)

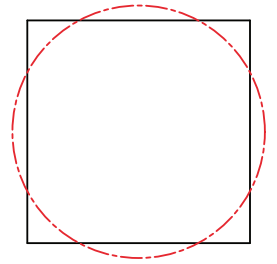

For special **toothed and ribbed** tools, for inner slots, the hole must be finished with a diameter that is 2 or 3 tenths larger than the inner diameter of the tothing as it is **recommended to not machine** the entire broaching tool profile, both not to create a greater accumulation of chips that could create a plug before finishing with machining as well as to decrease the force of the tool itself and therefore keep it in good conditions.

As for roughing, the solutions are 3:

- 1) Pre-machining of profile with a tool of lower section, and remove about half of the material, so that the removal be done in two times reducing stress for tool.
- 2) Proceed near grooves with some pre-drillings in order to remove as much as possible the material before using Poliangolar tool, then make the center hole and then enter by Poliangolar tool.
- 3) instead of the above pre-holes recommended, use a roughing cutter: in this way the material removed would be even bigger, and you may already work with the center hole on size. If possible, the best solution is the third, the alternative is the second solution, and if not possible, you can use the first solution, but it means you have 2 devices and replace the tool on the device used at each processing.



When working on a CNC lathe, in most cases it is not possible to use the pulling lever as normally other machining is performed prior to or after the use of the Poliangular.

In this case the broaching can still be performed starting the machining in another manner, as described below:

- With the spindle turning at approx. 50/100 rpm, place the tool on the part to

be machined and enter approx. 1 mm with a F0.1 feed in order to machine all of the tool edges and, only when arriving at this depth, start with the speed and feed values suitable for the machining process.

An example of numerical control programming is shown below:

G0 = fast speed

G1 = working speed

M3 = clockwise rotation

M4 = anticlockwise rotation

F = feed mm/rev

S = rotations rpm

N1 G0 X0 Z1 S100 (Poliangular positioned at 1mm from part zero)

N2 G1 Z-1 F0.1 (The punch creates an impression sufficient for pulling)

N3 S1500 (optimal rotation example)

N4 G1 Z-21 F0.05 (end of machining with optimal feed)

N5 G1 Z1 F3 (return with fast but not rapid feed)

Possible problems

- The machining may be slightly twisted
- The machining is equal to the diameter specified by the geometry
- Impossible to phase the punch with the part

Possible solutions

- a) Increase the speed/feed ratio to the advantage of the second
- b) Avoid bevelling (influences pulling)
- c) Increase the depth of the impression (point N2)
- d) Divide the machining into multiple parts, inverting the direction of rotation

es. N4 S1500 **M3** Z-7 F0.03

N5 **M4** Z-14

N6 **M3** Z-21

N7 G1 Z1 F3

- e) Position 2 pins in place of the forks



- f) Used motorised: in this case, the pulling lever can be fit and the machining will be exactly like the work centre

For normal devices in series N models **0500 - 1100 - 2100 and 3100**, the maximum working depth is theoretically 25 mm, as 25 mm is the total protrusion of the tool, but the thickness of the support flange must be considered and therefore approx. 3 mm. must be deducted, therefore the effective working depth will be approx. 22 mm., whereas for the **0200N** series, with a protrusion of 15 mm, the effective depth will be 12 mm., and for the **0100N** series, with a protrusion of 10 mm., the effective depth will be 7 mm.

The same applies to series S devices, such as **3100S**, whose effective working depth is 42 mm.

Then there is the **4100XS** series, which uses tools with a tool protrusion from the shaft surface of 70 mm, for an effective depth of 67 mm.

For all tool types, please note that after a certain section, the flange is removed because of the through sharpening,



therefore all working depths can be increased by approx. 2 mm.

Devices for external profiles can reach the following depths: for model 0200E - 15 mm, for **5100E** and **7100E** - 32 mm, for model **8100E** - 52 mm and for **9100E** - 77 mm



It is very difficult to recommend exact working speeds and feeds, as they depends on various factors such as the type and **dimension of the broaching** to be performed (hexagonal, square, ribbed or toothed), the type of material used (soft, alloy steels or stainless steel etc.), the **type of finishing** to be obtained and finally the also the **type of machine tool** used, which must be sufficiently rigid and suitable to support strong axial thrusts and therefore it is not possible to declare how long the tool will last.

We have noticed that at higher speeds, better finishing results are obtained, but it is recommended not to use them when working parts are too far from the tightening point (projecting parts) as they generate their own machining vibration due to the oscillation of the tool, which has an impact not only on the finishing but also on the duration of the tool. Whereas with regard to the feed, it should be stated that the tool will remain in contact with the part and it will be worn less by remaining within certain limits to not cause early breakage, and it is always recommended in the case of doubt to previously perform tests on soft or easy to machine materials.

Theoretically, to start well and as an initial approach to the machining, we recommend starting at a speed of 1200-1400 rev, with a feed of F 0.03 mm/rev, and once the obtained part is checked, the parameters can be corrected to obtain the best result possible.

The most frequent case of having to make changes to the speed and/or feed is when working soft material, such as mild cutting steel or aluminium, as during the penetration phase, the tool carrying shaft pulling friction can exceed the cutting force and the **machining may be slightly twisted**. In this case, **reduce the speed and increase the feed**.

This situation only occurs if the **pulling lever is not used**.

The duration of the Poliangular tool is directly influenced by the conditions of use, if more or less correct, the characteristics of the material to be machined (quality and resistance) and the quantity of material removed based on the section to be created.

To make it **last longer**, and to ensure perfect centring, proceed as follows:

- use a machine tool that is sufficiently rigid and suitable for supporting strong feed thrusts, which could cause vibrations and/or bending
- good precision of the machine tool to ensure that the coaxiality will be maintained while machining between the Poliangular device and the part to be machined.

Duration can be extended by regularly checking the device's cutting wire and by sharpening it from the front before the edges are excessively worn; the trimming must be performed level ("zero" rake).

Resharpener the tool will cause its cutting section to be reduced progressively, the amount of the reduction corresponds as follows to each **tenth of a millimetre removed**:

0,007 ÷ 0,008 for NG series tools

0,005 ÷ 0,006 for SG series tools

On the contrary, the matrixes for external profiles have a cutting section that increases progressively with sharpening by 0.009 - 0.01 mm for each tenth of a millimetre removed.

Example :

If you must resharpen a hexagonal 14 mm tool series NG16 with standard tolerances (+0.05 - +0.1) before reaching the nominal dimension of 14 mm. a minimum of 0.6 to a max. of 1.3 mm must be removed. From what is described above, you can see that the more you increase the range of construction tolerance for a larger tool, the resharpening and use margin will increase.

As the cutting section must be maintained concentric to the axis of the part, the tool protrusion from the support surface on the spindle shaft must remain constant at 25 mm. (10 for 0100N, 15 for 0200N, 45 for the SG series, 70 for the XG series).

In the opposite case, compensate with a ground washer (available commercially) to be fit on the leg of the tool to restore this measurement.

However in practice when the shortening does not exceed approx. 1 mm. it is not important to insert the washer as perceptible machining differences will not be detected.

Flat tool sharpening is normally what produces the best efficiency and greater duration in general, but when machining certain types of steel, such as stainless (without components that increase its workability) better results can be obtained with different rakes as shown below:

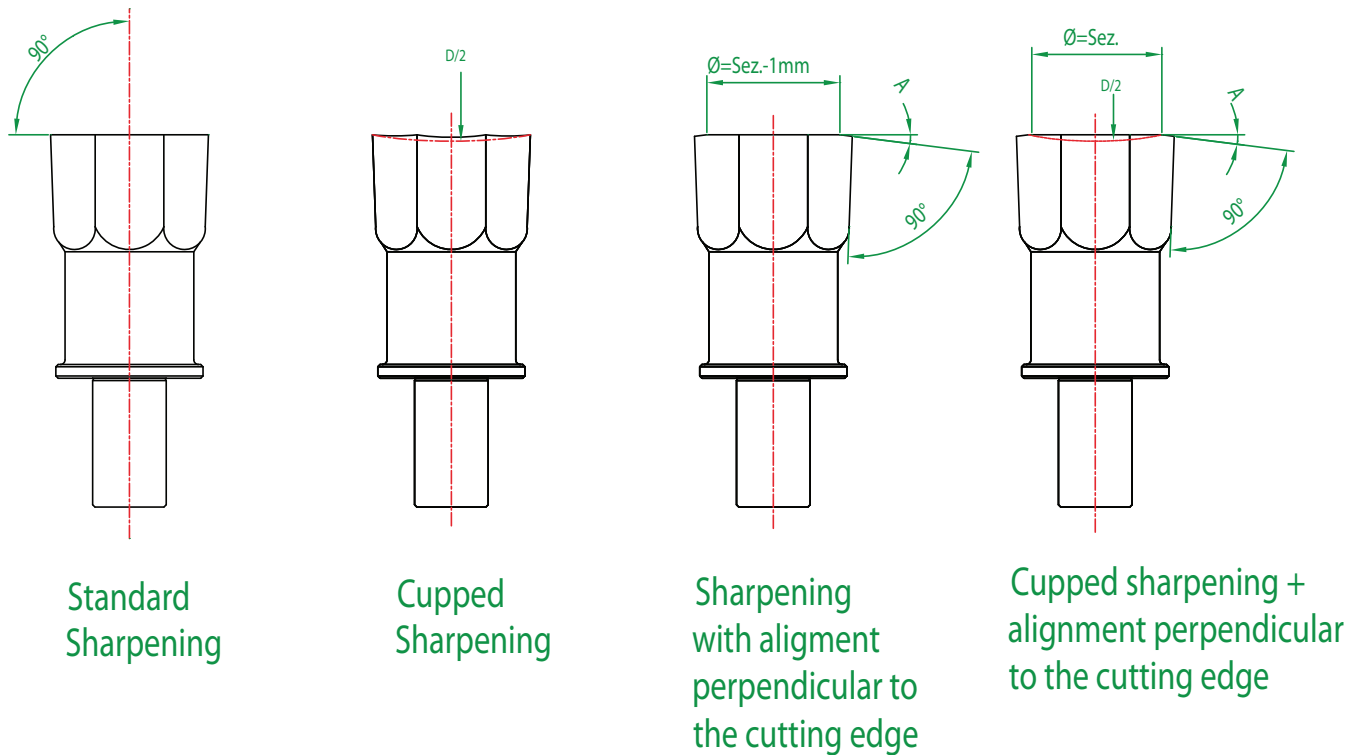

Resharpener and all operations that involve the tool must be done with abundant lubrication to prevent an increase in temperature and resulting decarbonisation, which would make the tool very fragile.

With difficult machining, it may be useful to use tools with a specific **coating**, which in most cases can be **TIN-PVD** or **TIALN**. The use of one of these coatings is recommended as the tools become more resistant to the heat produced by the machining and to wear and as a result extend their life.



The **TIN-PVD** coating reduces wear and the tendency for seizing and produces an anti-adherent effect during machining, and is recommended for soft materials such as aluminium alloys.

The **TIALN** coating can also support greater thermal loads and better results have been obtained when machining abrasive (superalloys, cast iron) and harder (steel alloys, stainless steel and titanium) materials.

TOOL BREAKAGE OR CHIPPING

The most frequent causes of breakage or chipping of the tool edges are:

- 1) **imperfect coaxiality** with the part to be machined, in this case the tool is not damaged when it penetrates the pre-hole but in the successive return phase, when the bending action due to the imperfect centring stops.
- 2) **insufficient pre-hole depth** therefore the material removed during machining, and which is pushed downwards, does not permit the tool to reach the preset depth and therefore the edges are strongly strained against the blind bottom.
- 3) **Twisting of the machining** when the pulling lever is not used, and also in this case the breakage occurs when returning, as the edges are located in a different position than when machining started.

MACHINING LARGE SIZED PROFILES

When machining square profile keep in mind that the quantity of material to be removed is more than double the amount for a hexagonal slot, therefore, the machine is stressed more, therefore these procedures normally require a very rigid and powerful machine.

When possible, and especially with a square greater than mm.14, a few measures can be implemented:

- a) the pre-hole must always be as large as possible
- b) if the square section (**S**) must have four complete surfaces, the quantity of material to be removed can be reduced by first making **small holes (d)** in correspondence of the four edges and then the central pre-hole (**D**)
- c) when possible **round off the edges** in order to remove the sharp edge, which is the most fragile point of the tool and also the section that tends to break or chip first. In this way, most of the material is removed and the slot can be made, also quicker, and with a better finish.

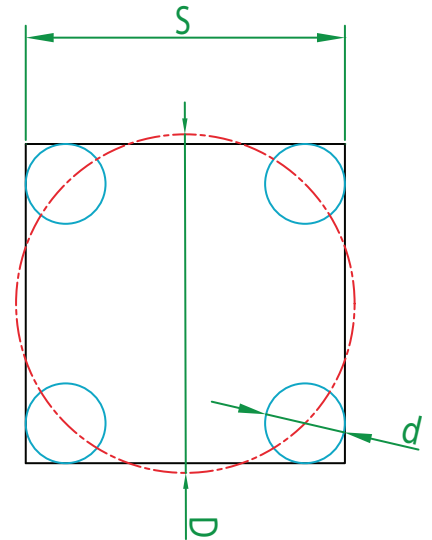

Of course, the same considerations apply to large sized hexagonal slots (usually above 27-28 mm.)

Taking the above into consideration, any polygonal slot can be machined such as stellar, grooved or involute, always providing that the quantity of material to be removed lies within the permitted limits of the machine or machining times.

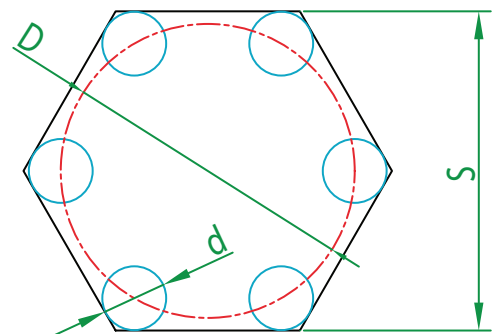

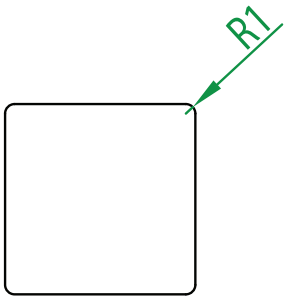

Edges
with radius

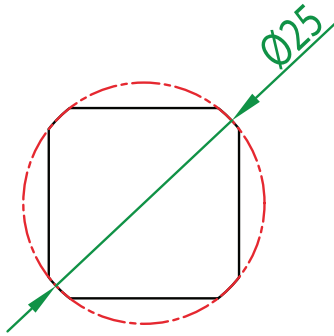

Edges with
sharpened
diameter

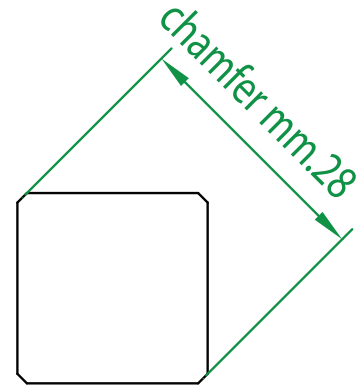

Chamfered
edges

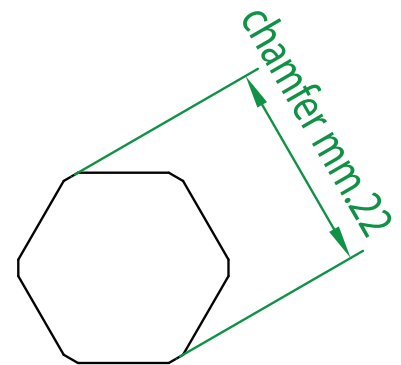
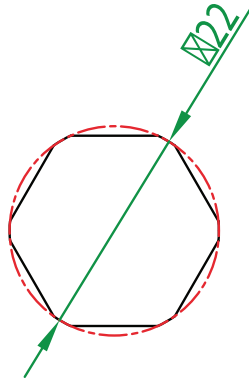
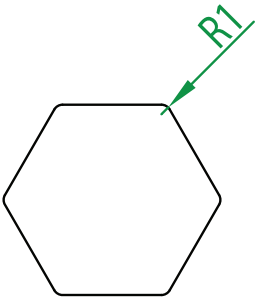

Pre-holes for the execution of square profiles

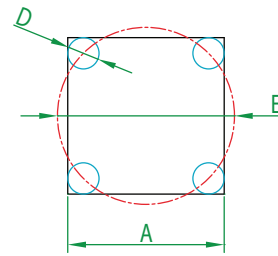
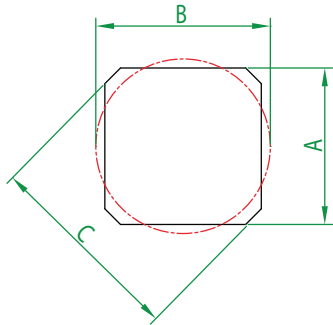

Measure A H11	Ø pre-hole B	Ø interaxis C
20	21	26,4
21	22	27,7
22	23,1	29
23	24,1	30,3
24	25,2	31,7
25	26,2	33
26	27,3	34,3
27	28,3	35,6
28	29,4	36,9
29	30,4	38,3
30	31,5	39,6
31	32,5	40,9
32	33,6	42,2
33	34,6	43,5
34	35,7	44,9
35	36,7	46,2
36	38,8	47,5
37	39,8	48,8
38	40,9	50
39	41,9	51,3
40	43	52,6
41	44	53,9
42	45,1	55,2
43	46,1	56,5
44	47,2	57,9
45	48,2	60,2
46	49,3	61,5
47	50,3	62,9
48	51,4	64,2
49	52,4	65,5
50	53,5	66,9

Measure A H11	Ø Rough-holes D	On diameter E
20	4,75	21,4
21	5	22,4
22	5,3	23,45
23	5,5	24,5
24	5,75	25,6
25	6	26,65
26	6,25	27,7
27	6,5	28,8
28	6,7	29,85
29	6,95	30,9
30	7,2	32
31	7,45	33
32	7,7	34,1
33	7,9	35,15
34	8,15	36,25
35	8,4	37,3
36	8,65	38,35
37	8,9	39,4
38	9,15	40,5
39	9,4	41,6
40	9,7	42,65
41	9,9	43,7
42	10,2	44,8
43	10,45	45,9
44	10,7	47
45	10,9	48
46	11,15	49,1
47	11,4	50,15
48	11,75	51,25
49	12	52,3
50	12,3	53,4

Pre-hole for the execution of hexagon profiles

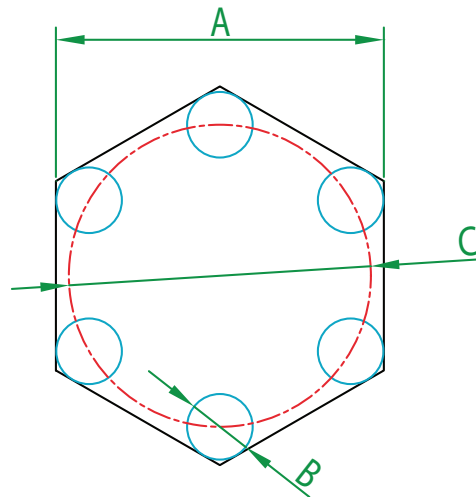

Measure A H11	Ø of 6 holes B	Ø interaxis C
30	8,3	23
31	8,6	24,8
32	8,9	25,6
33	9,2	26,4
34	9,5	27,2
35	9,8	28
36	10,1	28,8
37	10,3	29,6
38	10,6	30,4
39	10,9	31,2
40	11,2	32
41	11,5	32,8
42	11,8	33,6
43	12	34,4
44	12,3	35,2
45	12,6	36
46	12,9	36,8
47	13,1	37,6
48	13,4	38,4
49	13,7	39,2
50	14	40
52	14,6	41,6
55	15,4	44
58	16,2	47,2
60	16,8	48

Pre-holes and diagonals for the execution of double square profiles

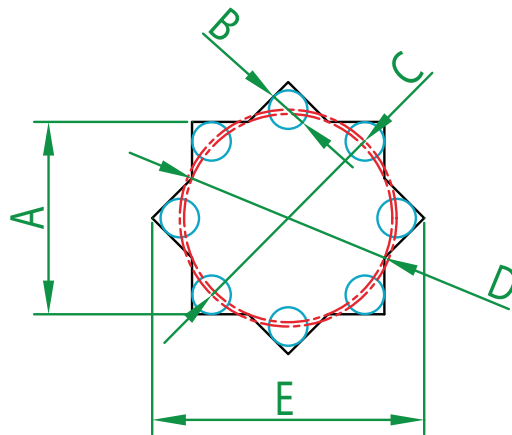

Mesasure A H11	Ø of 8 holes B	Interaxis C	Ø of central hole D	Diagonal of tool E
10	2,50	9,85	11,10	13,20
11	2,75	10,80	12,20	14,50
12	3,00	11,80	13,35	15,90
13	3,25	12,80	14,50	17,20
14	3,50	13,80	15,60	18,50
15	3,75	14,80	16,70	19,80
16	4,00	15,75	17,80	21,10
17	4,25	16,70	18,90	22,50
18	4,50	17,70	20,00	23,70
19	4,75	18,70	21,10	25,10
20	5,00	19,70	22,30	26,40
21	5,25	20,70	23,40	27,70
22	5,50	21,60	24,50	29,00
23	5,75	22,65	25,60	30,40
24	6,00	23,60	26,70	31,70
25	6,25	24,60	27,80	33,00
26	6,50	25,60	29,00	34,30
27	6,75	26,55	30,00	35,60
28	7,00	25,60	31,20	37,00
29	7,25	28,55	32,30	38,30
30	7,50	29,50	33,40	39,60
31	7,75	30,50	34,50	41,00
32	8,00	31,50	35,60	42,30
33	8,25	32,50	36,70	43,60
34	8,50	33,50	37,90	44,90
35	8,75	34,50	39,40	46,20
36	9,00	35,40	39,40	46,20
37	9,25	36,40	42,30	48,90
38	9,50	37,30	42,50	50,40
39	9,75	38,30	43,70	51,80
40	10,00	39,20	44,00	53,20

Pre-hole for the execution of TORX profiles and overall dimensions

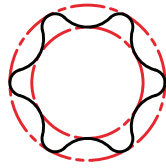

TORX type	Pre-hole -0/+0,15	External diameter	Internal diameter	Depth	TORX type
T5	Ø mm. 1,2	1,50	1,12	0,50	T5
T6	Ø mm. 1,4	1,77	1,29	0,50	T6
T7	Ø mm. 1,6	2,06	1,51	0,51	T7
T8	Ø mm. 1,9	2,39	1,80	0,71	T8
T9	Ø mm. 2,0	2,57	1,88	0,81	T9
T10	Ø mm. 2,2	2,82	2,07	0,89	T10
T15	Ø mm. 2,9	3,35	2,80	1,02	T15
T20	Ø mm. 3,2	3,94	3,05	1,27	T20
T25	Ø mm. 3,6	4,52	3,48	1,40	T25
T27	Ø mm. 3,8	5,08	3,66	1,91	T27
T30	Ø mm. 4,4	5,61	4,30	2,52	T30
T40	Ø mm. 5,2	6,76	5,05	2,92	T40
T45	Ø mm. 5,9	7,87	5,68	3,02	T45
T50	Ø mm. 6,8	8,94	6,60	3,02	T50
T55	Ø mm. 8,3	11,3	8,07	3,56	T55
T60	Ø mm. 10,0	13,44	9,67	5,21	T60
T70	Ø mm. 11,5	15,72	11,24	6,50	T70
T80	Ø mm. 13,2	17,81	12,85	7,45	T80
T90	Ø mm. 14,8	20,23	14,43	8,65	T90
T100	Ø mm. 16,5	22,44	16,05	9,85	T100