



850x1000 HERKULES X-CNC

80x1,6



850



850*

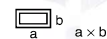

1000x850



1000x460



3x400V 50 Hz



11,0



15-80



9490x80x1,6

	Lmin	Lmax	B	Hmin	Hmax	V	Kg
	4760	6280	3140	2820	3260	620	11 800
PILA / BAND SAW	Lmin 4830	Lmax 6280	B 1680	Hmin x	Hmax x		Kg 7300
PODAVAČ / FEEDER	Lmin 3600	Lmax x	B 1910	Hmin x	Hmax x		Kg 4250



OPTION
STANDARD

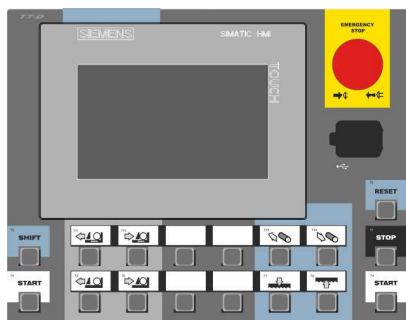
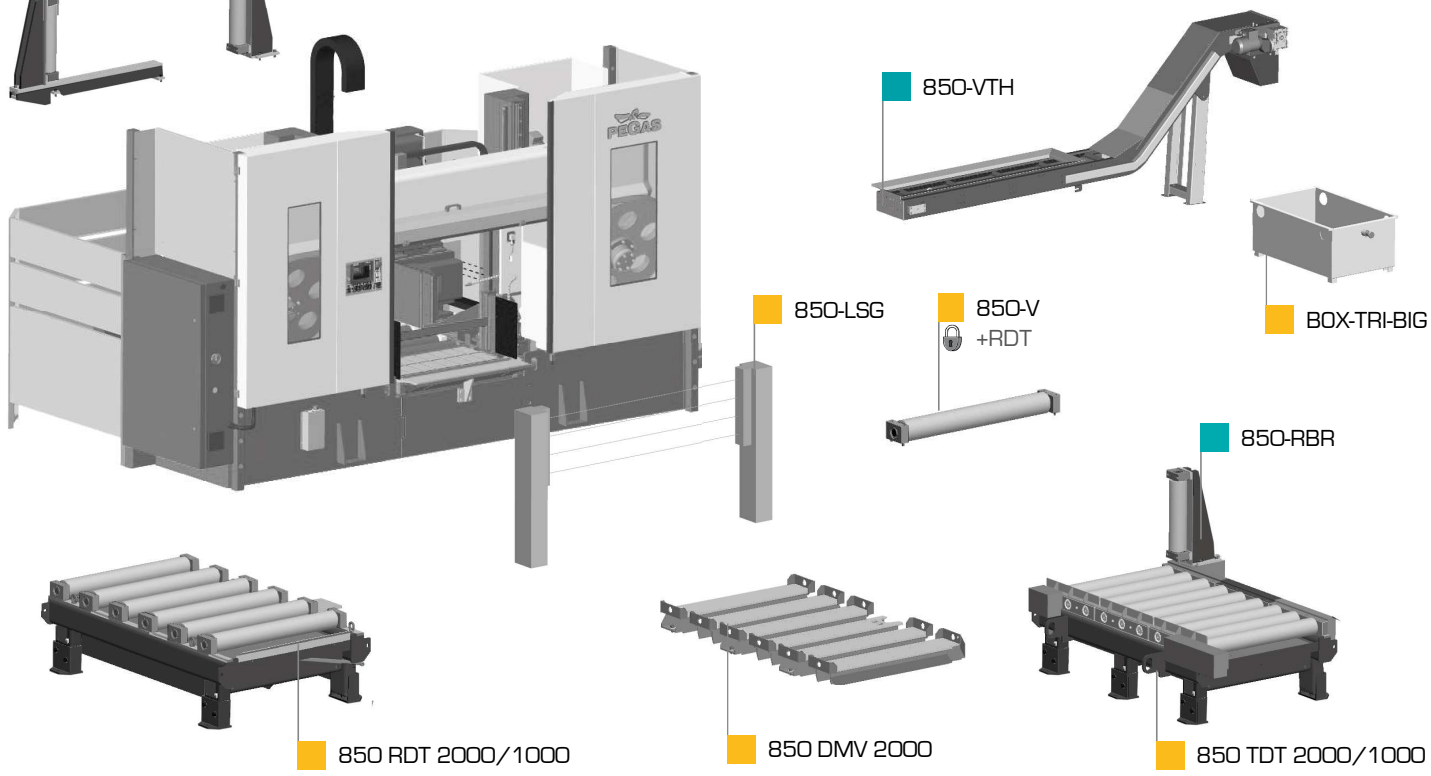
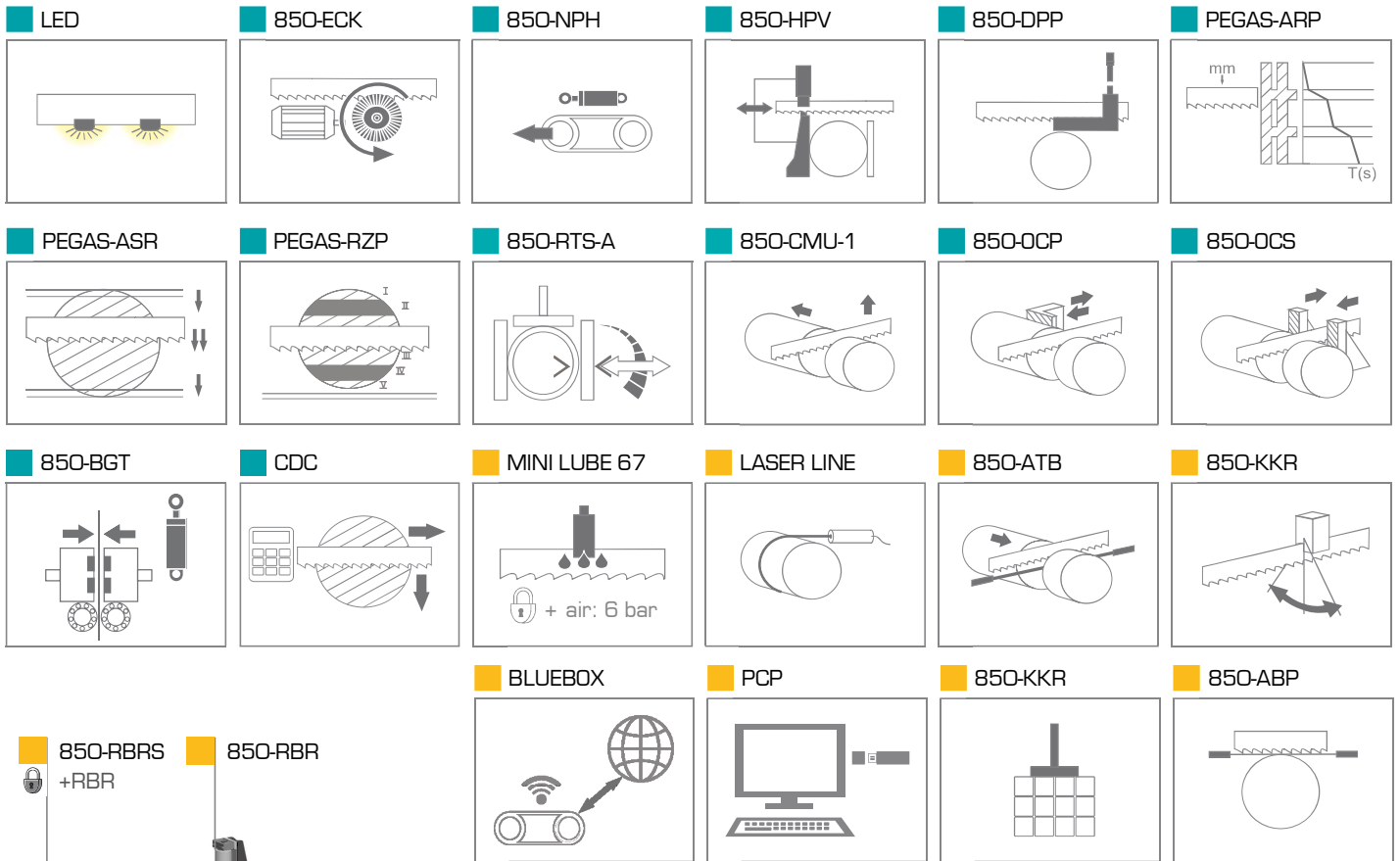

CONTROL PANEL: SIEMENS (X-CNC)

850x1000 HERKULES X-CNC

- výrobce si vyhrazuje právo provádět změny
technických údajů, technické údaje odpovídají 1.1.2020
/ producer has the right to make changes of technical data,
technical data are valid on 1.1.2020

- pila na fotografii není vždy v základním provedení,
uvedené rozměry odpovídají stroji v základním provedení
/ the machine in the picture is not always in the basic version,
mentioned diameters are for machine in basic version

* doporučená hodnota. Při překročení doporučeného
maximálního průměru není možné garantovat výkon
pilového pásu!
/ recommended value. The blade performance cannot
be guaranteed
when the recommended diameter is exceeded!

 - řezání svazků bez horního přitlaku
/ cutting of the bundle without top clamping



PEGAS - GONDA s.r.o.
Čs.armády 322, 684 01 Slavkov u Brna,
CZECH REPUBLIC

www.pegas-gonda.cz
00420-544 221 125 (126) | pegas@gonda.cz