



700x750 HERKULES X-CNC

67x1,6



700



700*

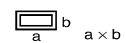

750x700

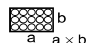

750x460



3x400V 50 Hz



11,0



15-80



7680x67x1,6



10000

Lmin
4350

Lmax
5700

Bmin
2010

Bmax
2500

H
2800

V
615



700x750
HERKULES X-CNC

OPTION
STANDARD

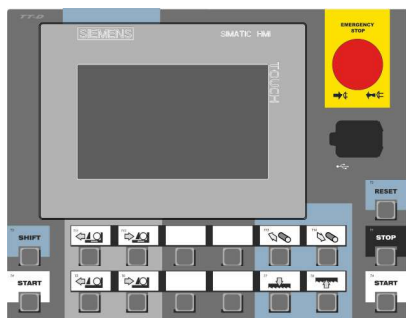
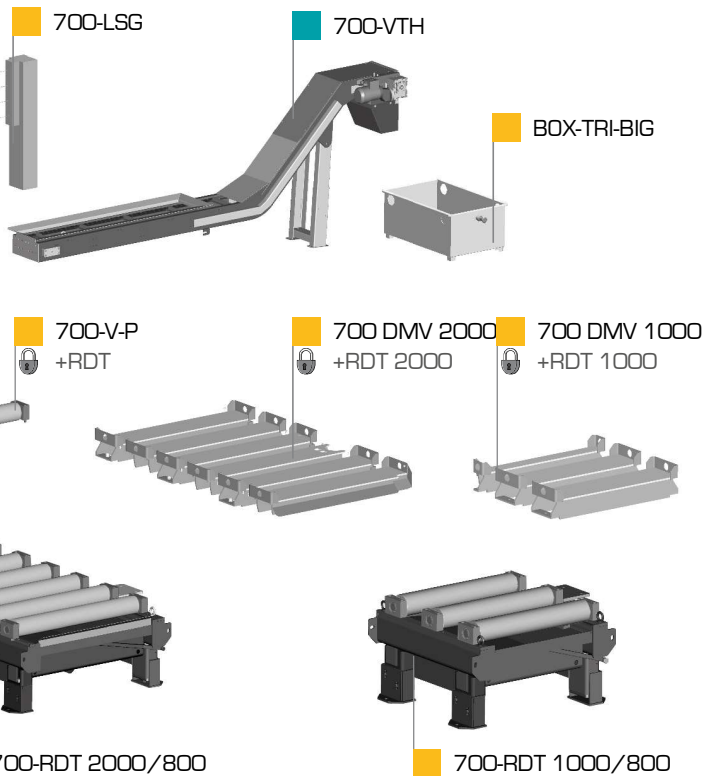
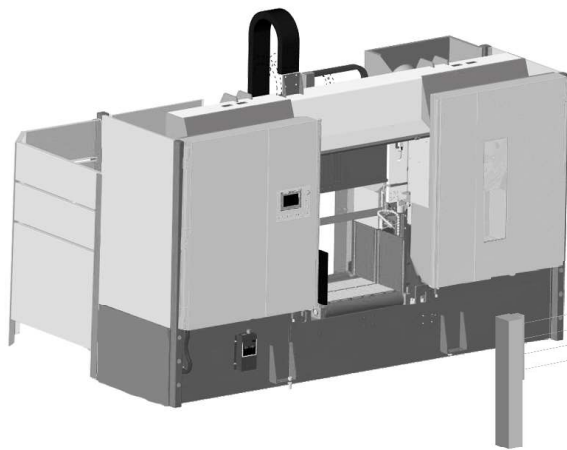
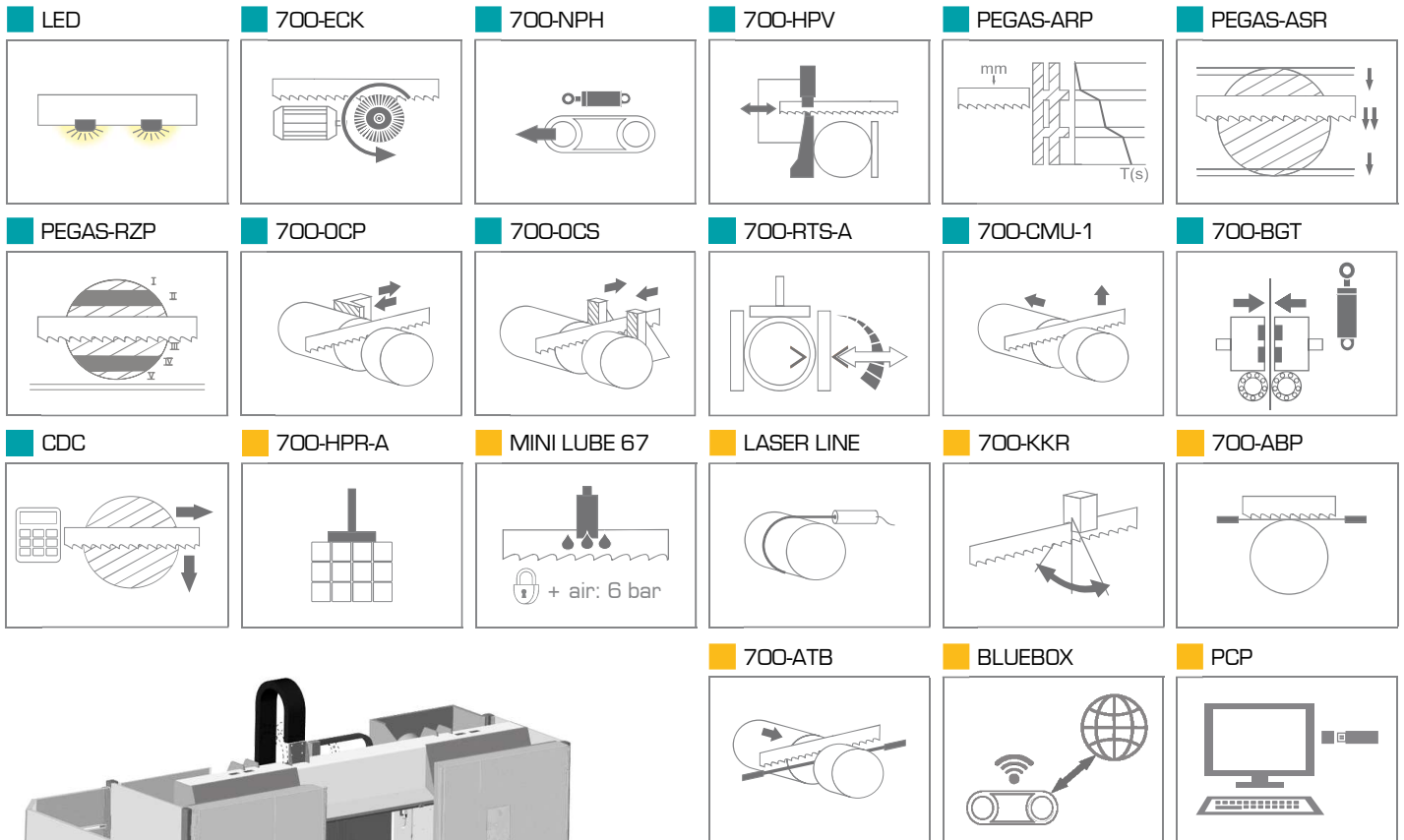

CONTROL PANEL: SIEMENS (X-CNC)

700x750 HERKULES X-CNC

- výrobce si vyhrazuje právo provádět změny
technických údajů, technické údaje odpovídají 1.1.2020
/ producer has the right to make changes of technical data,
technical data are valid on 1.1.2020

- pila na fotografii není vždy v základním provedení,
uvedené rozměry odpovídají stroji v základním provedení
/ the machine in the picture is not always in the basic version,
mentioned diameters are for machine in basic version

* doporučená hodnota. Při překročení doporučeného
maximálního průměru není možné garantovat výkon
pilového pásu!
/ recommended value. The blade performance cannot
be guaranteed
when the recommended diameter is exceeded!

- řezání svazků bez horního přitlaku
/ cutting of the bundle without top clamping



PEGAS - GONDA s.r.o.
Čs.armády 322, 684 01 Slavkov u Brna,
CZECH REPUBLIC

www.pegas-gonda.cz
00420-544 221 125 (126) | pegas@gonda.cz