

350x400 A-CNC-LR

	\varnothing 0°	∇ 45°	∇ 60°	∇ 45°	∇ 60°	$\frac{b}{a \times b}$
	350	320	x	320	x	x
	250*	180*	x	180*	x	x
	400x350	330x120	x	330x120	x	400x210

3x400V	3,0	20-100	4520x34x1,1	1325	
L	Bmin	Bmax	Hmin	Hmax	V
2300	1900	2350	1570	2500	940

*doporučené hodnoty/recommended values

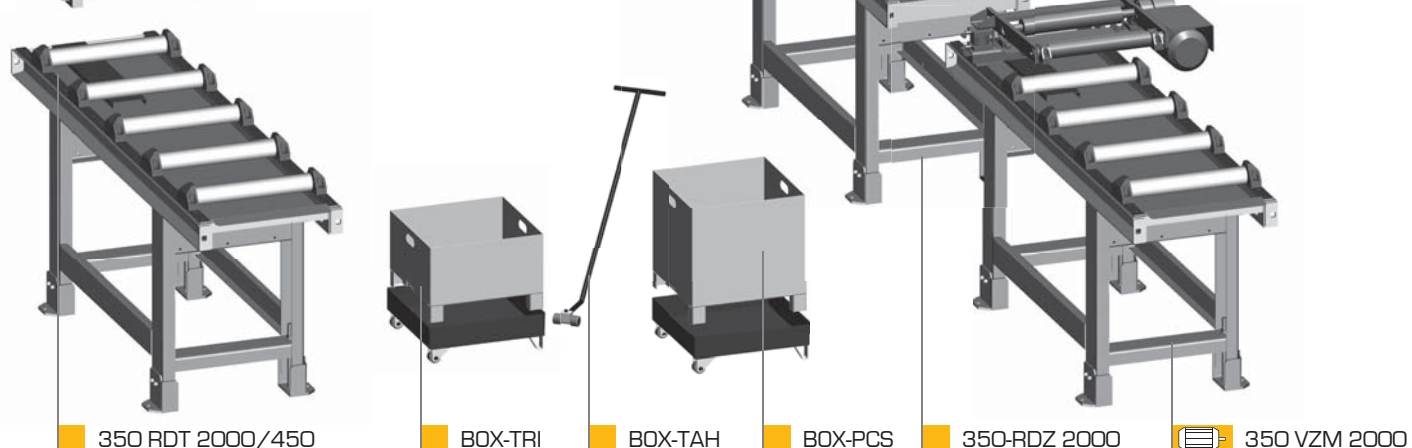
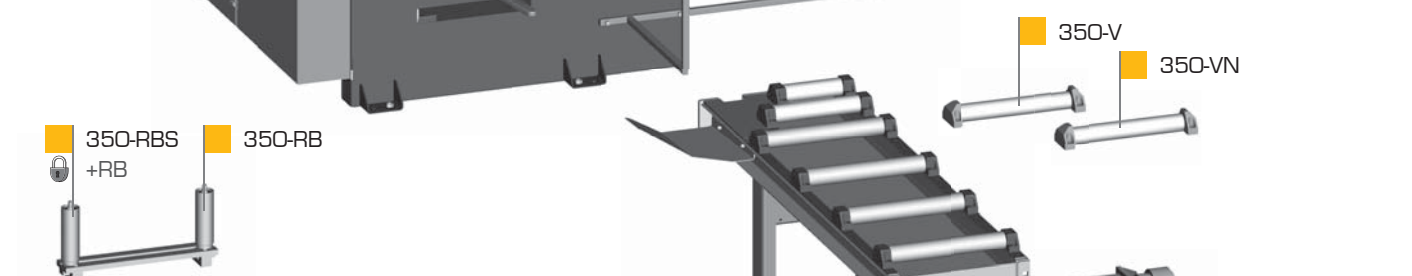
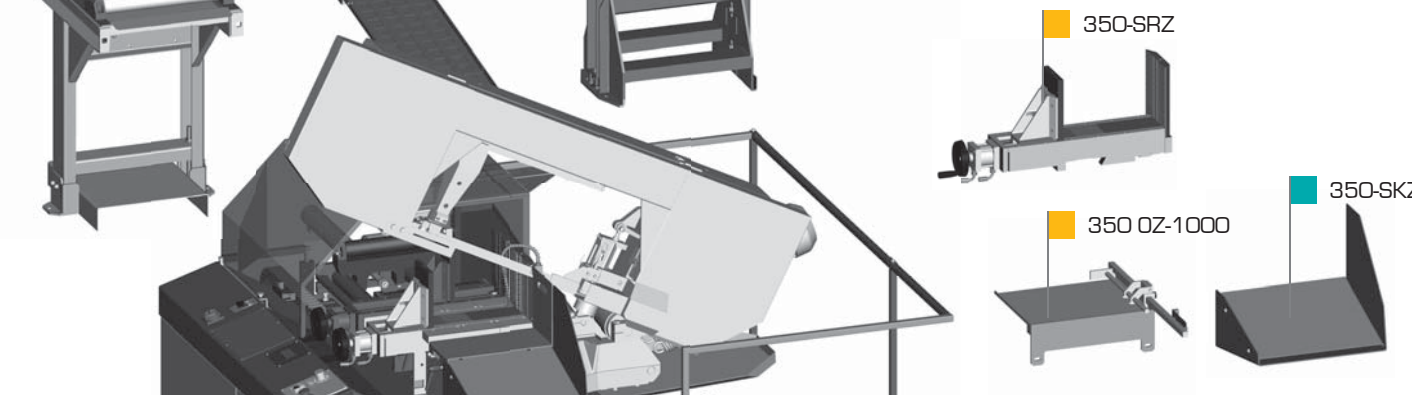
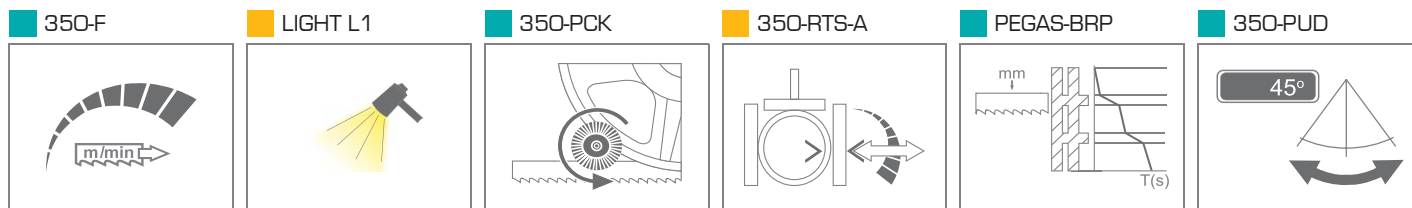

350x400 A-CNC-LR

STANDARD OPTION



PEGAS-GONDA s.r.o., Čs.armády 322, 684 01 Slavkov u Brna, CZECH REPUBLIC
 Tel: 00420-544 221 125 (126), Fax: 00420-544 227 389, E-mail: pegas@gonda.cz
 www.pegas-gonda.cz

- výrobce si vyhrazuje právo provádět změny technických údajů, technické údaje odpovídají 1.5.2015
 / producer has the right to make changes of technical data, technical data are valid on 1.5.2015 /
 - píla na fotografii není vždy v základním provedení, uvedené rozměry odpovídají stroji v základním provedení
 / the machine in the picture is not always in the basic version, mentioned diameters are for machine in basic version /

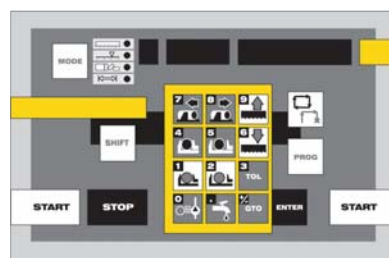

CONTROL PANEL: SAW MICRO