

















**230x280 GH-LR** **27x0,9**

	 0°	 45°	 60°	 45°	 60°	
	230	190	120	185	x	x
	150*	110*	80*	110*	x	x
	280x220	180x170	120x90	180x120	x	280x120
						
3x400V 50 Hz	0,9/1,4	35/70	2720x27x0,9	320		
<b>L</b>	<b>B</b>	<b>Hmin</b>	<b>Hmax</b>	<b>V</b>		
1610	890	1320	1950	787		



230x280  
GH-LR

OPTION  
STANDARD

230-M2V

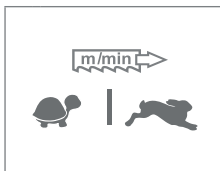

240-CK

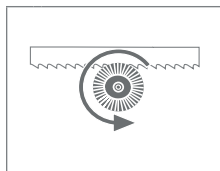

MINI LUBE 27-34

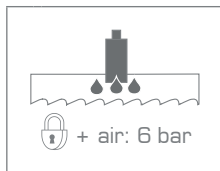

LASER LINE

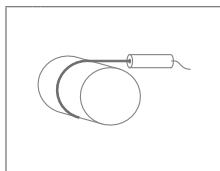

R 290

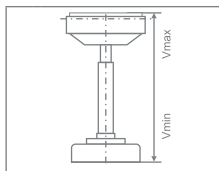

	S (mm)	Vmin (mm)	Vmax (mm)
R	290	760	980

RB 200



RBS 200/290 +RB

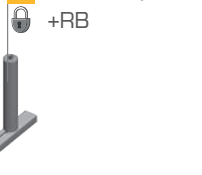

RHS 290 +RBS+RB



OZD 1000

OZD 2000  
OZD 3000  
OZD 4000  
OZD 5000  
OZD 6000

OZ 1000

OZ 2000  
OZ 3000  
OZ 4000  
OZ 5000  
OZ 6000

OZ 0000



230-RDP

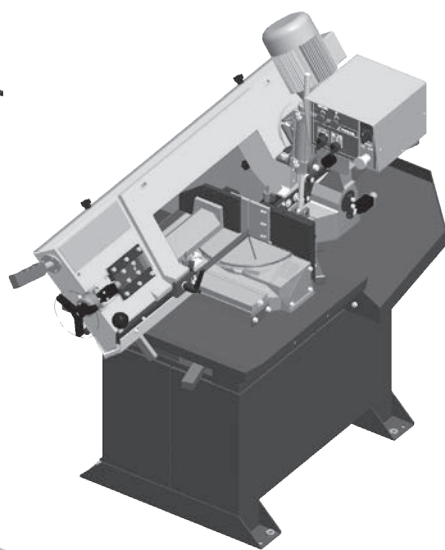

230-OZM



RD VR-290

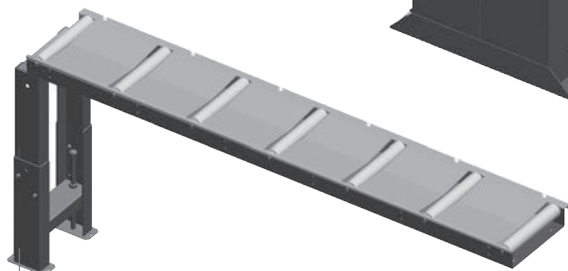

230-RDZ

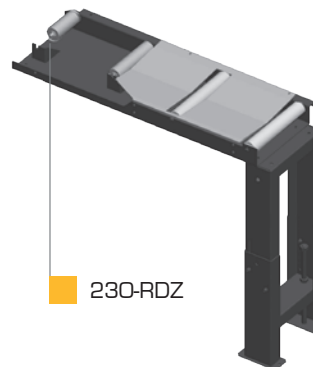

RDN

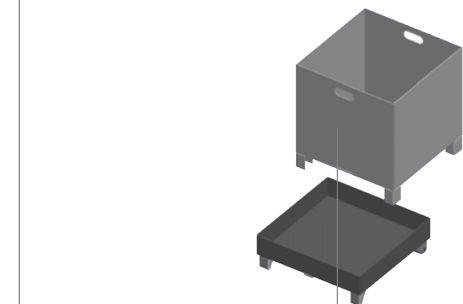

RD 2000/290

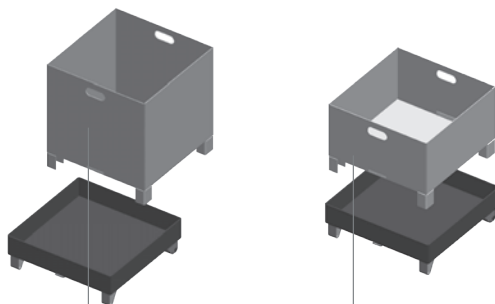

BOX-PCS

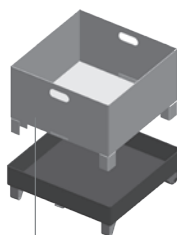

BOX-TRI



BOX-TAH

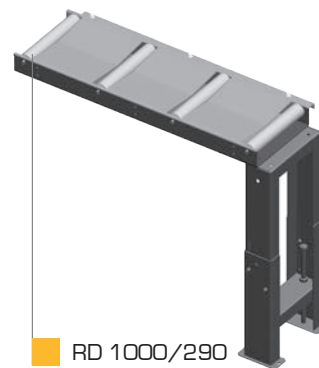

RD 1000/290

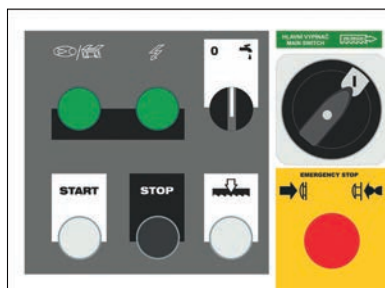

CONTROL PANEL: GH-LR

## 230x280 GH-LR

- výrobce si vyhrazuje právo provádět změny technických údajů, technické údaje odpovídají 1.1.2021 / producer has the right to make changes of technical data, technical data are valid on 1.1.2021

- pila na fotografii není vždy v základním provedení, uvedené rozměry odpovídají stroji v základním provedení / the machine in the picture is not always in the basic version, mentioned diameters are for machine in basic version

\* doporučená hodnota. Při překročení doporučeného maximálního průměru není možné garantovat výkon pilového pásu!

/ recommended value. The blade performance cannot be guaranteed when the recommended diameter is exceeded!

☒ - řezání svazků bez horního přitlaku / cutting of the bundle without top clamping



PEGAS - GONDA s.r.o.  
Čs.armády 322, 684 01 Slavkov u Brna,  
CZECH REPUBLIC

www.pegas-gonda.cz  
00420-544 221 125 (126) | pegas@gonda.cz