



[www.insize.com](http://www.insize.com)

## **OPERATION MANUAL**

**ISL-A1/A5/A05**

**ISL-B1/B5**

**LINEAR SCALE**



## Requirements of the Working Conditions

1. Do not disclose it in the bitter sunshine or high temperature. The ambient working temperature should range from 0°C-40°C.
2. Be far away from the strong acid and alkali as well as the chemicals.
3. Keep the signal cable of the linear scale far from the power cords as possible.
4. Take the way of installation into consideration when using the device in the situations of high voltage, strong current or magnetic field. do well in isolating the haphazard signals and avoid the disturbance of such.

## Other Requirements

1. Offer a proper match between the installation interface and the electric signal interface when designing and applying the device.
2. Do not lay heavy blocks on the signal cable. Please bundle and fix the excessive signal cable if it is overlong and do ensure the workers and the equipment a favorable working path.
3. Make sure that the plugs of the signal cable are well and stably plugged onto the corresponding interface.
4. Design the application of the linear scale according to its effective travel range, and avoid the occurrence of surpassing the effective range and the damage of the device.
5. Do not let dust pile up on the linear scale and the read head or the track of the moveable body of the linear scale.
6. Be sure to turn off the power before unplugging the connector of the signal cable.

## Daily Maintenance

1. Check the device after uncovering the package. Please immediately contact the dealer as soon as possible if the components are not complete or the mal-function needs settling. Do not disassemble or modify it at your wishes.
2. Do not clean the dust on or around the read-head and the moveable body with forced strength or air, for it may result in the dust dropping in the interior of the moveable body.

## 1.Principle and application

The linear scale is a kind of transmission amplitude grating, and the principle is, when the opposite travel main grating and the subordinate grating occurs, the Moire grid/line is generated. This change will be transferred into electric signal through the precise photo-electric exchanger, and then the digital signal at the relative travel is output after it is processed by the signal processing circuit.

This product can be grating with Digital Readout and form a grating measuring system and perform precise and accurate travel measurement. In addition, it can be applied in the trades of processing and measuring: Equipment for processing: Lathe, Miller, Grinder and Electric discharge machine.

Instrument for measuring: Profile projector, Video measuring instrument, Tool maker microscope and so on.

## 2. Specification

		ISL-A1/A5/A05	ISL-B1/B5
Effective movement L (mm)		50~1000	50~3000
Maximum movement(mm)	$50 \leq L \leq 900$	L+30	
	$L \geq 950$	L+50	
Distance between holes(mm)	$50 \leq L \leq 900$	L+132	L+136
	$L \geq 950$	L+152	L+156
Length of the scale (mm)	$50 \leq L \leq 900$	L+149	L+154
	$L \geq 950$		
Length of the signal cable (M)		3.5;(L ≤ 150, 300 ≤ L ≤ 950)	3.5;(L ≤ 950)
		5;(L=200,250,1000)	5;(1000 ≤ L ≤ 1900)
			10;(2000 ≤ L ≤ 3000)
Thickness(mm)		21	29
Maximum velocity (M/min)		60	60
Working voltage (volt)		5±0.25	
Work waste		MAX. 5V, 40mA	
Reserving temperature(°C)		0~50	
Working temperature(°C)		0~40	

## 3. Output Signal

a) Two modes for outputting signal: TTL and RS422(differential type) signal, and the oscillogram is as follows:

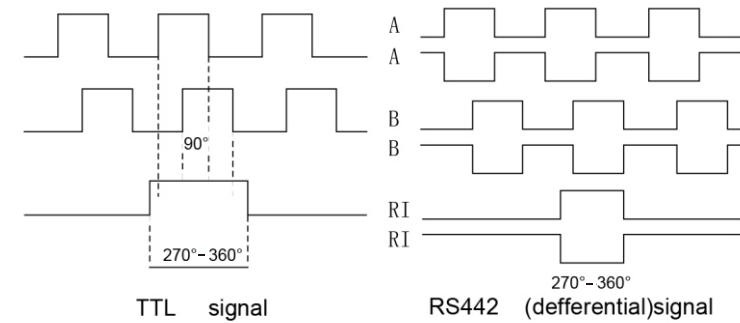

b) Referent Interface Circuit Diagram

The output signal interface circuit diagram is as follows:

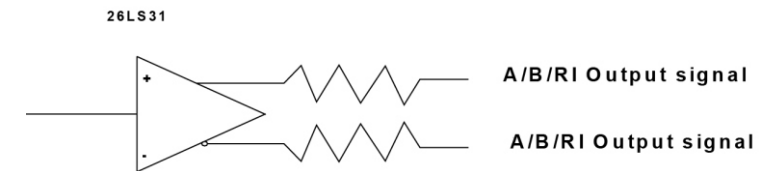

Propositional pairing interface circuit diagram

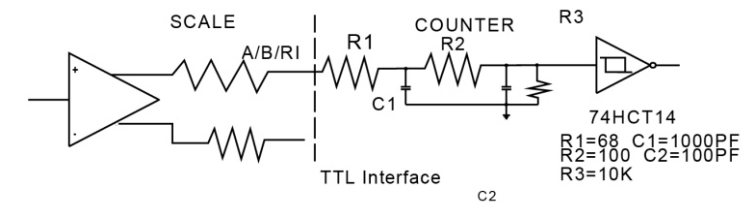

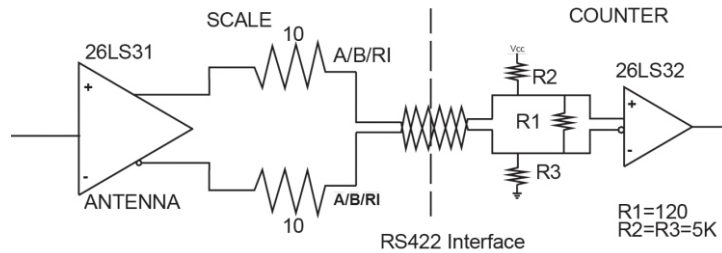

9pd-rs422 socket (opt)

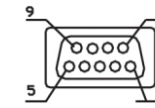

PIN	SIGNAL	Color of signal line	Attribute	Current
1	+5V	Red	Input	35mA
2	0V	Black	Input	35mA
3	A	Brown	Output	4mA
4	B	Yellow	Output	4mA
5	RI	Orange	Output	4mA
6	RI	Orange/White	Output	4mA
7	B	Yellow/White	Output	4mA
8	A	Brown/White	Output	4mA
9	FG	Weaving net		

## 4. Structure & Installation Figure

### c) Pin Position

Note: The 9PD-TTL is a standard socket and the others are optional.

9PD-TTL socket(opt)

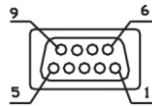

PIN	SIGNAL	Color of signal line	Attribute	Current
1	+5V	Red	Input	35mA
2	0V	Black	Input	35mA
3	A	Brown	Output	4mA
4	B	Yellow	Output	4mA
5	RI	Orange	Output	4mA
9	FG	Weaving net		

15PD-TTL socket(opt)

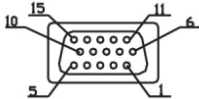

PIN	SIGNAL	Color of signal line	Attribute	Current
1	+5V	Red	Input	35mA
2	0V	Black	Input	35mA
3	A	Brown	Output	4mA
4	B	Yellow	Output	4mA
5	RI	Orange	Output	4mA
9	FG	Weaving net		

7-wire TTL socket(opt)

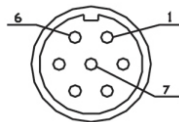

PIN	SIGNAL	Color of signal line	Attribute	Current
1	+5V	Red	Input	35mA
2	0V	Black	Input	35mA
3	A	Brown	Output	4mA
4	B	Yellow	Output	4mA
5	RI	Orange	Output	4mA
9	FG	Weaving net		

6-wire TTL socket(opt)

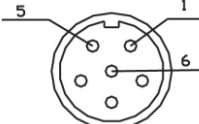

PIN	SIGNAL	Color of signal line	Attribute	Current
1	0V	Black	Input	35mA
2	A	Brown	Output	4mA
3	B	Yellow	Output	4mA
4	RI	Orange	Output	4mA
5	+5V	Red	Input	35mA
6	FG	Weaving net		

### a) Installation Figure

- Instruction figure of ISL-B1/B5 series linear scale. Take the effective range  $L \leq 900\text{mm}$  for an example.

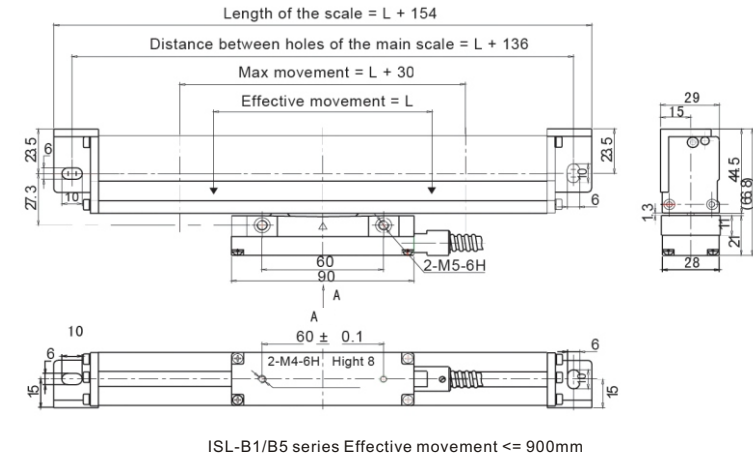

ISL-B1/B5 series Effective movement  $\leq 900\text{mm}$

### Relative dimensions of ISL-B1/B5 series linear scale

L	Max Range	Dist between Holes	Length of scale	Other Dimensions
$L \leq 900$	L+30	L+136	L+154	Refer to the figure above
$L > 900$	L+50	L+156	L+174	

- Installation figure of ISL-A1/A5/A05 series linear scale. Take the effective range  $\leq 900\text{mm}$  for an example:

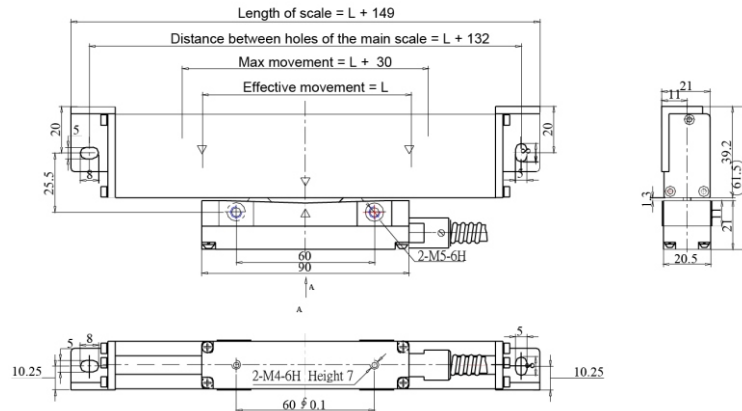

ISL-A1/A5/A05 series effective movement < 900 mm

#### Relative dimensions of ISL-A1/A5/A05 series linear scale

L	Max range	Distance betweenholes	Length of Scale	Other Dimensions
$L \leq 900$	L+30	L+132	L+149	Refer to the figure above
$L > 900$	L+50	L+152	L+169	

#### b) Parts Drawing

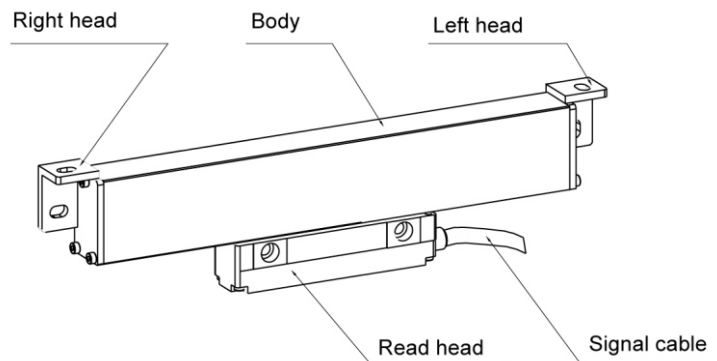

## 5. Installation

### a) Notice for Installation

The effective movement of the linear scale should be larger than the maximum travel of the worktable. If it is not long enough, change a longer one or install fixing blocks on the worktable. Not less than 10mm space should be spared between the end of the Read Head and the body of the scale. (Figure 4.1)

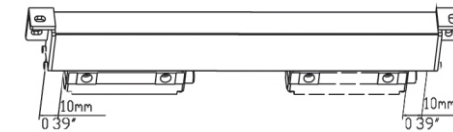

Figure 4.1

b) As to the installation surface of the linear scale, if it is not mechanical work surface, you should place a cushion on the back of the scale or self-made installation cushion. Only in this case can ensure the stability and reliability of the linear scale and installation surface.

c) When you calibrate the parallelism of the body of the linear scale with level meter or other similar devices, the angle of the measuring head must be confined within  $\pm 30^\circ$  (based on the measuring head of the level meter being parallel with the level meter itself). As for the angle, the smaller, the better. If you use the decimal meter (Figure 4.5, 4.6, 4.8, 4.9), you must make the bar of the measuring head perpendicular with the surface to be measured, only in this case can ensure the actual measuring precision.

d) Please closely consider the following factors when selecting the position where the linear scale to be installed:

Select mechanical work surface as the installation surface.

The groove of the linear scale must avoid the direct shock of metal powder, oil, water and dust (Figure 4.2).

The length of the L-board, in the possible conditions, the shorter the better, and the bearing pressure of the installation surface of the L-board must be taken into close consideration, as well as the L-board Serial Read Head and the interface of the moving worktable.

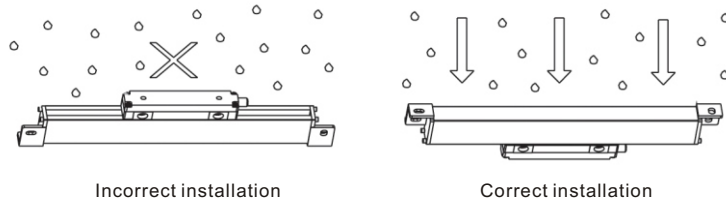

Figure 4.2

- e) More than 0.5mm space must be spared between the dust-proof cover and the body of the scale. Allow no contact between them when moving the scale.

The screw thread of the installation hole must have a, at least, 6-threading die screwing depth. The part which bears more pressure such as the fixing board for supporting the DRO, must have a, at least, 8-threading die screwing depth. ISL-A1/A5/A05 series linear scale is tightened with M4 screw, and ISL-B1/B5 with M5. After drilling holes on the installation surface, you have to smooth the granulated surface and clean the paint and the stains(Figure 4.4).

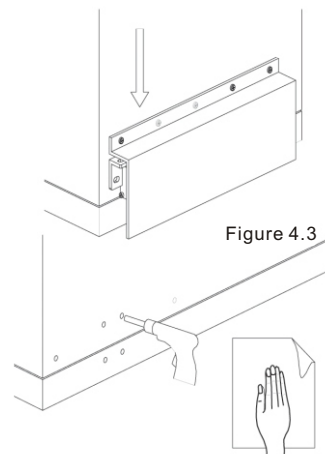

Figure 4.4

- f) You must consider all the relevant moving distance before fixing the signal cable. The fixing position should be placed in the middle of the track as possible as you can. And then well bundle the surplus cable.
- g) Make sure that the ground wire is grounded, and measure from the cover of the Read Head to the ground terminal of the signal processing device with a volt-ohm meter (the ground connector of the DRO). confirm the resistance is not more 0.3Ω(Resistance  $\leq 0.3\Omega$ ).

- h) Based on the center of the linear scale, you must take the point of symmetry of the two sides as the criteria point when adjusting the height and level of the linear scale. As to any linear scale, whenever you perform the horizontal adjustment or vertical adjustment, for the body of the linear scale itself, the range of the adjustment can't individually exceed 20mm from the end of the meter to the body of the scale (Figure 4.5). As for the Read Head, perform the adjustment within the two square standard sides (Figure 4.6)

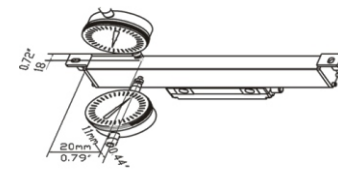

Figure 4.5

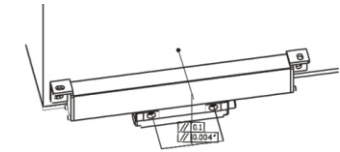

Figure 4.6

- i) The crooked radius of the signal cable should be more than 60mm.

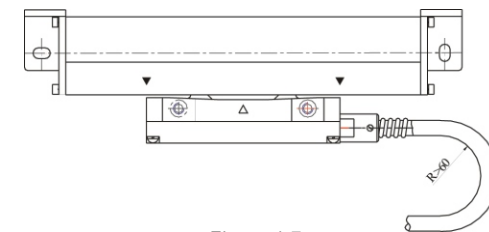

Figure 4.7

## 6. Standard of Installation

- a) The standard of installing the referent surface (Figure 4.8 a,b,c 3 ways of installation)
- The installation surface of the body is parallel with that of the Read Head. The parallelity is less than 0.1mm.
  - The installation surface of the body is perpendicular with that of the Read Head. The perpendicularity is less than 0.1mm.

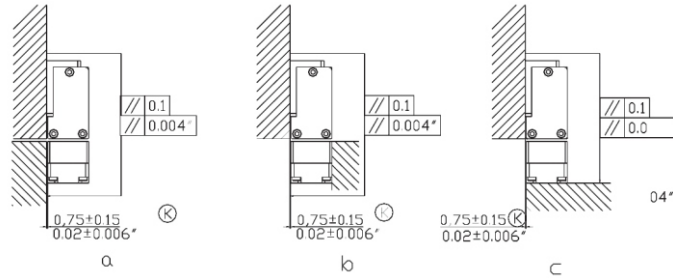

Figure 5.1

b) Standard of the Body (Figure 4.9, 4.10)

The parallelism of the height referring to the track of the worktable is less than 0.1mm, and the maximum can't surpass 0.15mm. Based on the point of symmetry, the smaller, the better. When the effective movement of the body is greater than 950mm, its linearity should be less than 0.1mm.

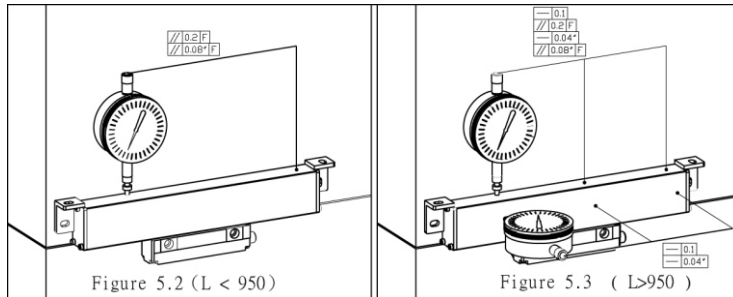

Figure 5.2 (L < 950)

Figure 5.3 (L > 950)

c) Standard of Read-Head

The interval between the read-head and the body of the scale should range from 0.8mm to 1.6mm. Use a cushion to adjust the interval when installing the read-head after it is well installed, draw out the cushion (Figure 4.11).

The  $\alpha$  side of the read-head and the  $\beta$  side of the body disturb horizontally. The value  $\Delta$ : ISL-B1/B5:  $0.5 \pm 0.15$ mm ISL-A1/A5/A05:  $0.25 \pm 0.15$ mm.

The parallelism of the read-head referring to the worktable is less than 0.10mm, and the maximum parallelity can't exceed 0.15 (Figure 4.6)

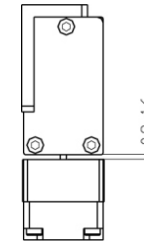

Figure 5.4

d) Notice:

In the figures, R indicates the crooked radius; F: the track of the worktable; L: the effective movement of the linear scale; K: the installation dimensions.