

# DIAL TEST INDICATORS

**INSPECTION  
CERTIFICATE**  
TRACEABLE TO NIST

**JEWELLED  
BEARING**

- Meet DIN2270 (except **2380-02**, **2381-02**)
- Jeweled bearing
- Carbide contact point
- Two measuring directions
- Anti magnetic body
- Supplied with two clamps: diameter Ø4mm and Ø8mm
- Optional accessory: styli (page 109)

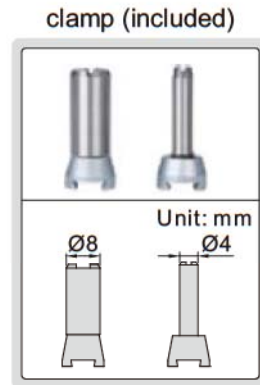

**2380-08**

(mm)

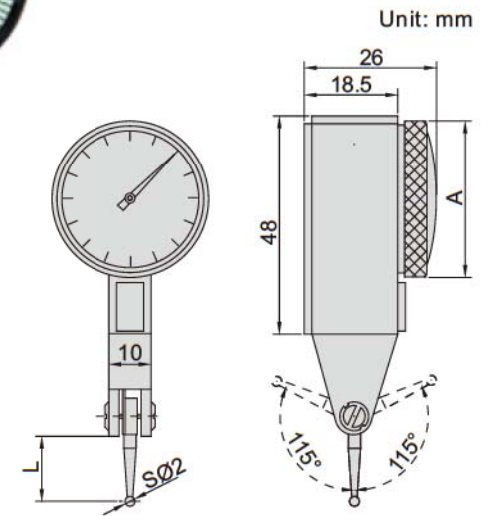

Code	Range	Graduation	Accuracy	Hysteresis	Dial reading	A	L
<b>2380-08 *</b>	0.8mm	0.01mm	13µm	3µm	0-40-0	Ø30	13.5
<b>2381-08 *</b>	0.8mm	0.01mm	13µm	3µm	0-40-0	Ø37	13.5
<b>2380-02 *</b>	0.2mm	0.002mm	6µm	2µm	0-100-0	Ø30	12.5
<b>2381-02 *</b>	0.2mm	0.002mm	6µm	2µm	0-100-0	Ø37	12.5

\* Supplied with manufacturer inspection certificate traceable to NIST USA