

PERSONAL  
ORDER DATA  
156 SET  
SERIES METRIC

SET CODE KW-BROACH  
15618 6-8  
BUSH 18,19  
20,22,24,25,28,30,32

15623 6-8-10  
BUSH 18,19

20,22,24,25,28,30,32,32(IV),34,35  
36,38

15626 5-6-8-10  
BUSH 15,16,17,18,19

20,22,24,25,28,30,32,32(IV),34,35  
36,38

15630 4-5-6-8  
BUSH 11,12,14,15,16,17,18,19  
20,22,24,25,28,30,32

15634 6-8-10-12  
BUSH 18,19

20,22,24,25,28,30,32,32(IV),34,35  
36,38,40,42,44

15635 4-5-6-8-10  
BUSH 11,12,14,15,16,17,18,19

20,22,24,25,28,30,32,32(IV),34,35  
36,38

15656 2-4-5-6-8-10-12  
BUSH 6,7,8,9,10,11,12,14,15,16,17,18,19

20,22,24,25,28,30,32,32(IV),34,35  
36,38,40,42,44

All sets are including Accessories &  
Bushes that belong to the same Keyway  
broach type I,II,III or IV

CODE	SPARE SHIMS	QTY
31102	I	0
31103	I	1
31204	II	1
31205	II	1
31306	III	1
31308	III	1
31410	IV	2
31412	IV	2

156v1

TABLE OF CONTENTS  
(SET 15656)

CODE	TYPE	BUSH MM
22106	I	6
22107	I	7
22108	I	8
22109	I	9
22110	I	10
22211	II	11
22212	II	12
22214	II	14
22215	II	15
22216	II	16
22217	II	17
22318	III	18
22319	III	19
22320	III	20
22322	III	22
22324	III	24
22325	III	25
22328	III	28
22330	III	30
22332	III	32
22432	IV	32
22434	IV	34
22435	IV	35
22436	IV	36
22438	IV	38
22440	IV	40
22442	IV	42
22444	IV	44

CODE	TYPE	KW-BROACH MM
11102	I	2
11103	I	3
11204	II	4
11205	II	5
11306	III	6
11308	III	8
11410	IV	10
11412	IV	12

CODE	ACCESSORIES
99101	PLIER
99102	BRUSH
99103	OIL
99104	PUNCH
99105	INSERT
99106	OUTSIDE CASE

# Hassay Savage Broaches

156 SET SERIES METRIC

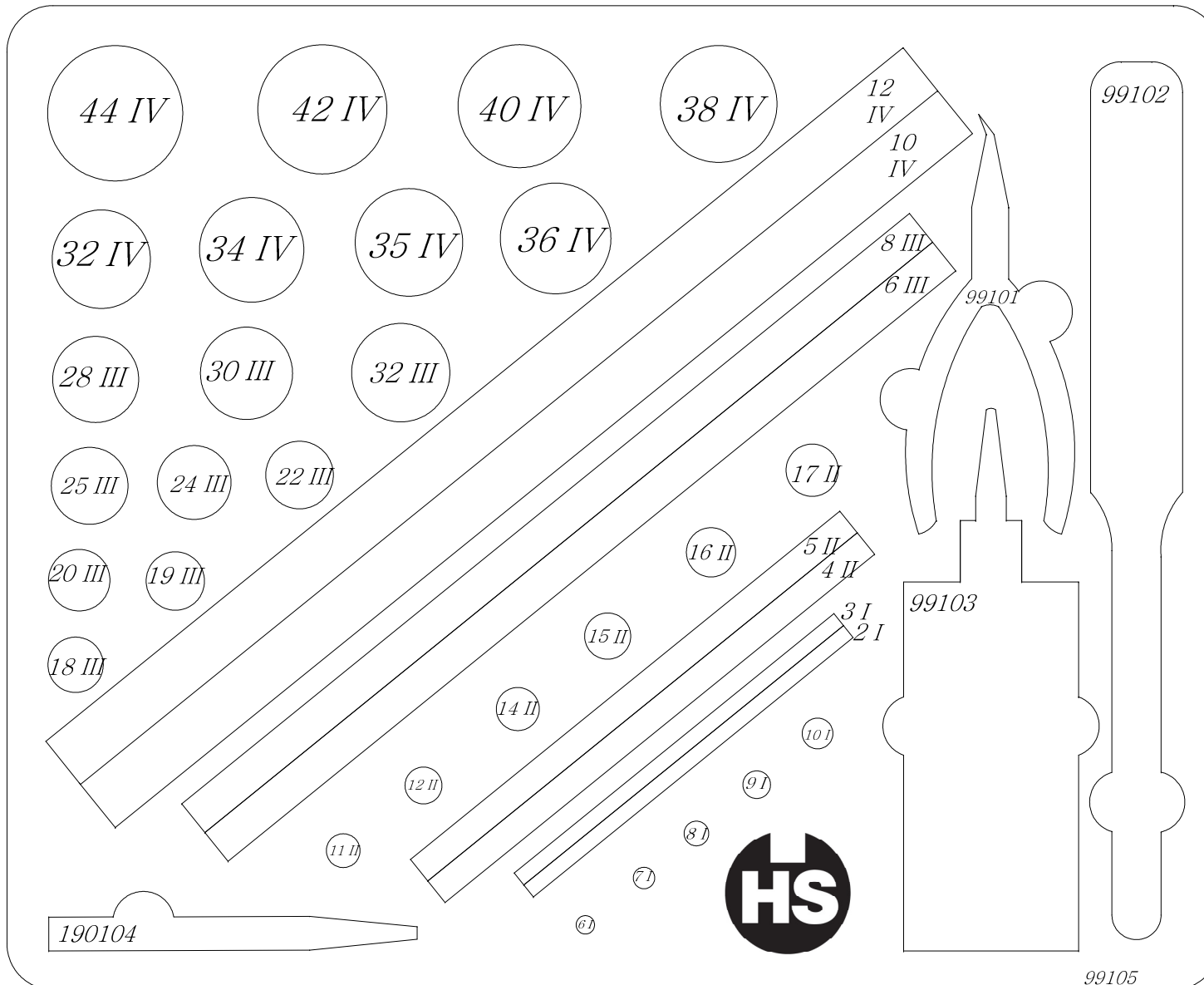

**156- series Same insert... Available in Personal Settings**

Onderstaande tabel geeft een overzicht welke spiebaanbreedte standaard bij welk gatdiameter thuishoort volgens DIN 6885, met daarbij de rugbreedte van de drukfrees en bus. \* **SPECIAAL BUSSEN OF FREZEN** voor overmaatse of ondermaatse spieën verkrijgbaar.

There is a review of which cutting width belongs to which hole diameter according to DIN 6885, with the back width of the broaches and bushings, mentioned in the table below. \* **SPECIAL Bushings and broaches** can be supplied on request.

**METRIC SIZES  
BROACHES AND BUSHINGS  
METRISCHE MATEN  
SPIEBAANDRUKFREZEN EN BUSSEN**

HOLE DIAMETER	BROACH WIDTH	STANDARD BACK WIDTH
DIAMETER GAT	SPIEBAAN BREEDTE	RUGBREEDTE STANDAARD
6 7 8	2	I
9 10	3	I
11 12 13	4	II
14 15 16 * 17 (III)	5	II * (III)
* 18 (II) * 19 (II) 20 22	6	III
24 25 26 27 28 30	8	III
* 32 (III) * 34 (III) * 35 (III) * 36 (III) 38	10	IV
40 42 44	12	IV
45 46 48 * 50 (V)	14	IV
* 52 (IV) * 54 (IV) * 55 (IV) 56 58	16	V
60 62 64 65	18	V
70 75	20	VI
80 85	22	VI * (24)
90 95	25	VI
100 105 110 115	28	VI

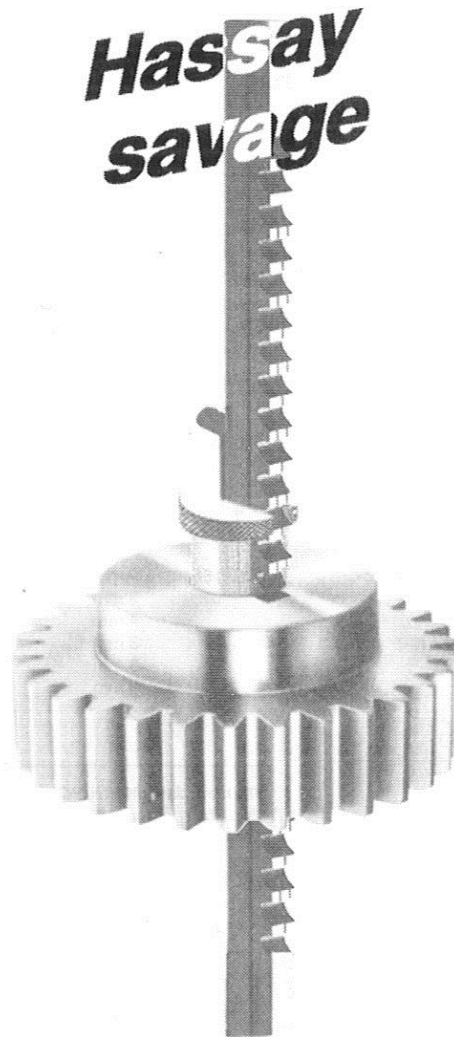

**INCH SIZES  
BROACHES AND BUSHINGS  
INCH MATEN  
SPIEBAANDRUKFREZEN EN BUSSEN**

HOLE DIAMETER	BROACH WIDTH	STANDARD BACK WIDTH
DIAMETER GAT	SPIEBAAN BREEDTE	RUGBREEDTE STANDAARD
1/4 5/16	1/16	I
3/8 7/16	3/32	I * (II)
1/2 9/16	1/8	II * (I)
9/16 5/8	5/32	II
5/8 11/16 * 3/4 (III) * 13/16 (III) * 7/8 (III)	3/16	II * (III)
15/16 1 1.1/16 1.1/8 1.3/16 1.1/4	1/4	III
1.5/16 1.3/8	5/16	III * (IV)
* 1.7/16 (IV) * 1.1/2 (IV) * 1.9/16 (IV) 1.5/8 1.11/16 1.3/4	3/8	III * (IV)
1.11/16 1.3/4 1.13/16 1.7/8	7/16	IV
1.13/16 1.7/8 1.15/16 2 2.1/16 2.1/8 2.3/16 2.1/4	1/2	IV
* 2.5/16 (IV) * 2.3/8 (IV) * 2.7/16 (IV) * 2.1/2 (IV) * 2.5/8 (IV) * 2.3/4 (IV)	5/8	V
* 2.7/8 (IV) * 2.15/16 (IV) * 3 (IV) 3.1/2 3.1/4	3/4	V
GROTERE BUSSEN OP AANVRAAG	7/8, 1, 1.1/8, 1.1/4 1.3/8, 1.1/2	VI

**VOORDELEN VAN DRUKFREZEN:**

- geen dure machine nodig, echter een universeel bruikbare brootspers.
- spiebanen zuiver op maat, nauwkeurigheid gecentreerd volgens DIN-normen.
- economisch, voor zowel een enkele spiebaan als voor seriewerk.
- één frees voor verschillende soorten materiaal, o.a. staal, gietijzer, aluminium, messing, etc.
- ongeschoolde krachten kunnen nauwkeurig spiebanen frezen.

**ADVANTAGES OF BROACHES:**

- no expensive equipment required, only a broachpress.
- very high accuracy according to DIN specifications.
- economic, for only one, but also for several keyways.
- only one broach required for several materials, such as steel, cast iron, aluminium, bronze, etc.
- low aducated personal is able to broach high accuracy keyways.

Standaard worden de drukfrees geleverd in kwaliteitslegering M2 met spaanhoek ±15°. Afwijkende type, kwaliteiten, passingen en spaanhoeken voor seriewerk op aanvraag