

Type 6582

SWIVEL BASE
FOR MACHINE VISES

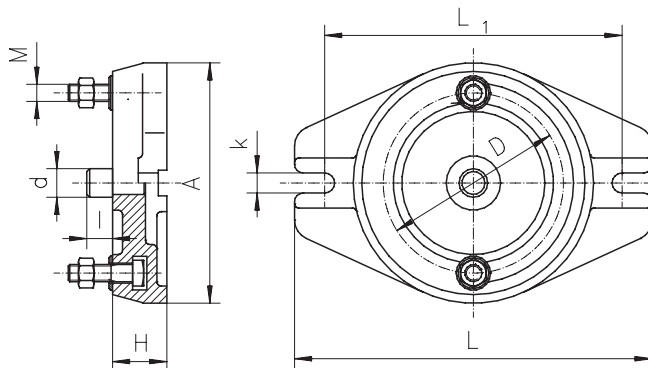
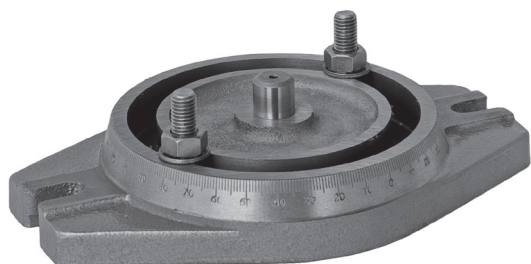

Features:

- Sturdy, cast iron design
- Ground contact edge
- Graduation
- Locating pin of high quality steel, hardened and ground
- Fixing screws

Code No.	Size	A	D	H	L	M	d	I	k	kg	For 6512
326582060900	2	168	126	45	250	M12	20	20	14	4,2	100,125
326582070000	3	212	150	50	290	M16	20	20	18	7	160
326582080200	4	286	210	55	400	M16	25	25	18	14,5	200
326582090400	5	360	260	55	460	M16	25	25	22	27,2	250

Type 6583

SWIVEL BASE
FOR MACHINE VISES

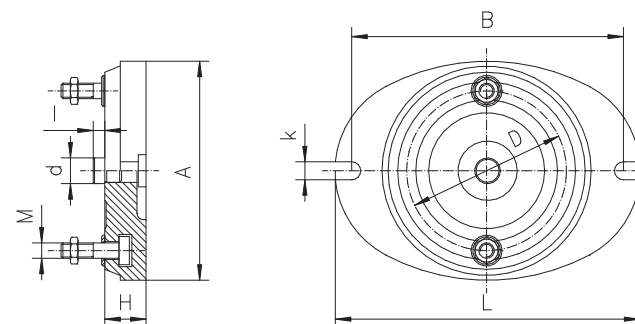

Features:

- Sturdy, cast iron design
- Ground contact edge
- Graduation
- Locating pin of high quality steel, hardened and ground
- Fixing screws

Code No.	Size	A	B	D	H	I	L	M	d	k	kg	For 6910
326583000600	2	170	211	124	32	9	237	M12	20	14	4,2	105
326583020000	3	245	294	184	38	16	328	M16	28	20	7,0	155
326583030100	4	300	357	265	47	35	405	M16	38	20	14,5	210

6582

6583