

6512

**MIT BEWEGLICHER BACKE
WITH MOVABLE REAR JAW**

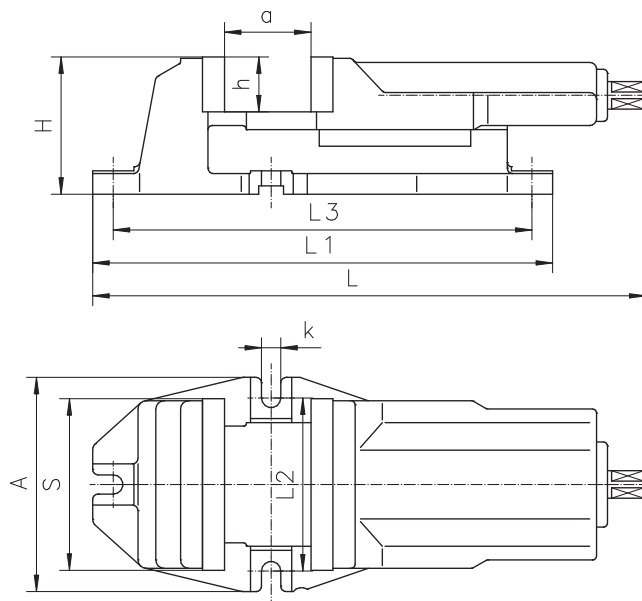

Artikel Nr. Code No.	Typ Type	S	A	H	L	L1	L2	L3	a	h	k	Max. Spannkraft [daN] Max. clamping force [daN]	kg
326512050600	6512-100	100	156	84	294	290	126	260	80	32	14	2.500	9,9
326512060800	6512-125	125	156	100	347	335	126	305	95	40	14	3.500	15,9
326512070000	6512-160	160	193	121	423	405	150	365	125	50	18	4.000	29,0
326512080100	6512-200	200	256	147	515	500	210	460	160	63	18	5.500	56,0
326512090300	6512-250	250	316	174	615	610	268	566	200	80	22	6.200	71,0

Eigenschaften:

- Die austauschbaren, gehärteten und geschliffenen Riffelbacken gewährleisten eine lange Lebensdauer
- Leitspindelabdeckung gegen Verschmutzung
- Körper und Backen aus hochwertigen Gussteilen gefertigt

Anwendung:

- Entwickelt für den Einsatz an Fräs- und Bohrmaschinen

Standardzubehör:

- Handkurbel
- Nutensteine

Features:

- Removable grooved jaw inserts are hardened and ground
- Lead screw protected against dirt and chips
- Body and movable jaw are high quality castings

Application:

- Designed for use with milling machines, drill presses, etc.

Standard accessories:

- Handcrank
- Slot nuts

Passende Drehplatte
Matching swivel base



Typ 6582 Seite 220
Type Page

Zubehör • Accessories 220-232

1
2
3
4
5
6
7

6512