

	S (mm)	Vmin (mm)	Vmax (mm)
R	390	760	980

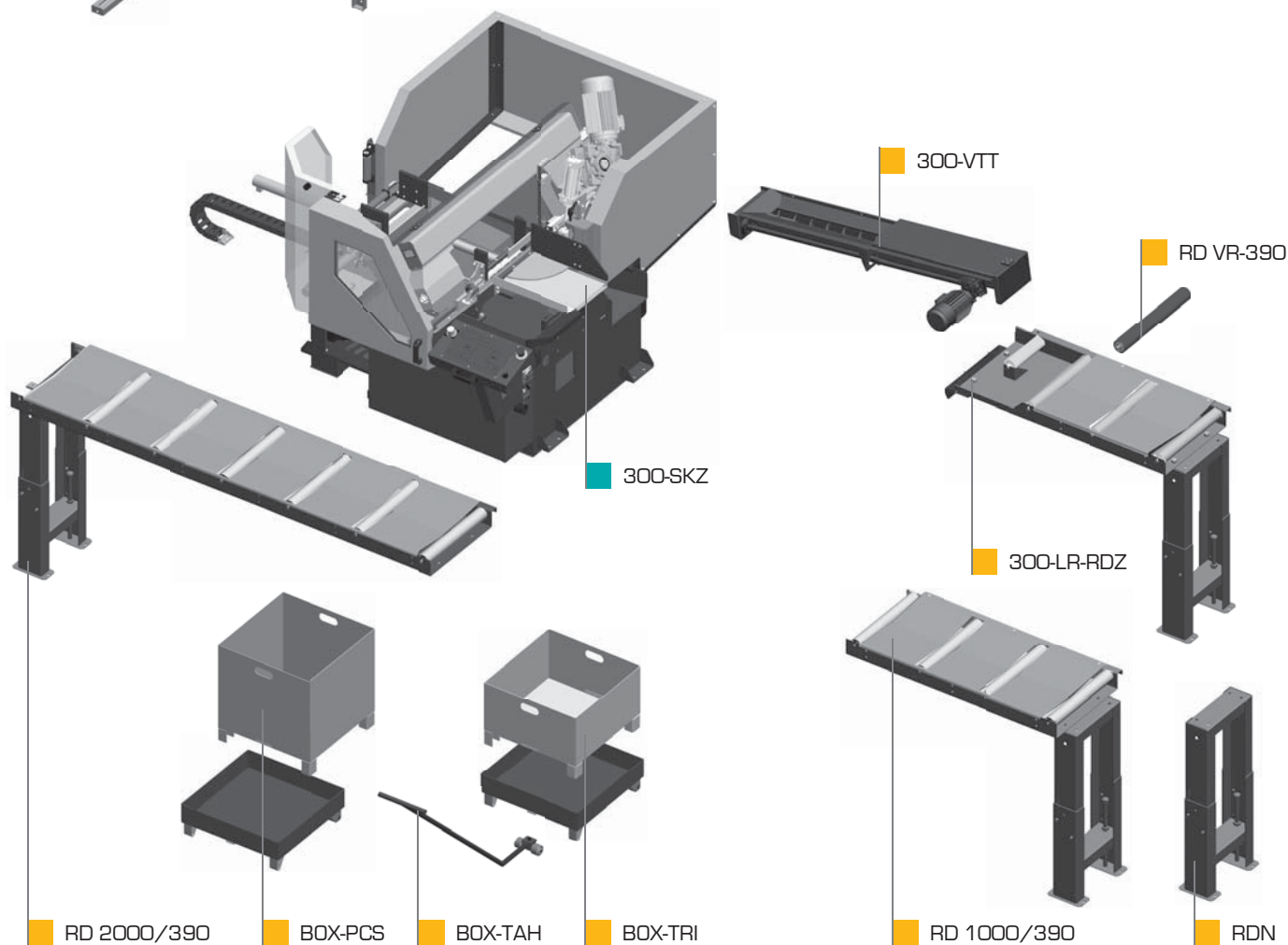

300x320 A-CNC-R

■ STANDARD ■ OPTION

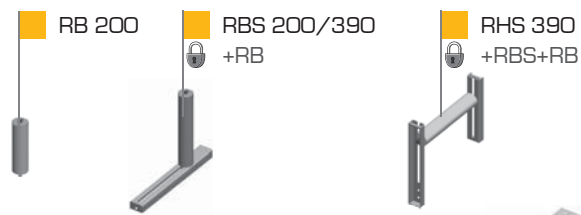

PEGAS-GONDA s.r.o., Čs.armády 322, 684 01 Slavkov u Brna, CZECH REPUBLIC
 Tel: 00420-544 221 125 (126), Fax: 00420-544 227 389, E-mail: pegas@gonda.cz
 www.pegas-gonda.cz

- výrobce si vyhrazuje právo provádět změny technických údajů, technické údaje odpovídají 1.5.2015
 / producer has the right to make changes of technical data, technical data are valid on 1.5.2015 /
 - pila na fotografii není vždy v základním provedení, uvedené rozměry odpovídají stroji v základním provedení
 / the machine in the picture is not always in the basic version, mentioned dimensions are for machine in basic version /

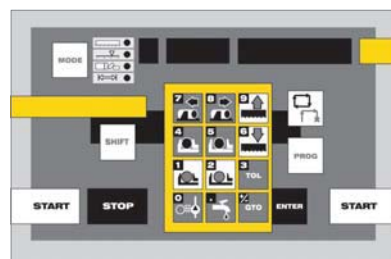

CONTROL PANEL: SAW MICRO