

Juego de cabezal de mandrinar micrométrico. DIN 228-A

Set of micrometric boring head. DIN 228-A

Utilización: Para mandrinar con precisión $\pm 0,01$ mm. y hasta $\varnothing 500$ mm.

Suministro: Un cabezal de mandrinar en un estuche de plástico + accesorios indicados abajo

Application: For precision boring $\pm 0,01$ mm. and up to $\varnothing 500$ mm.

Delivery: One boring head in a plastic box + A, B or C accessories indicated below.



40xx.JCM.50

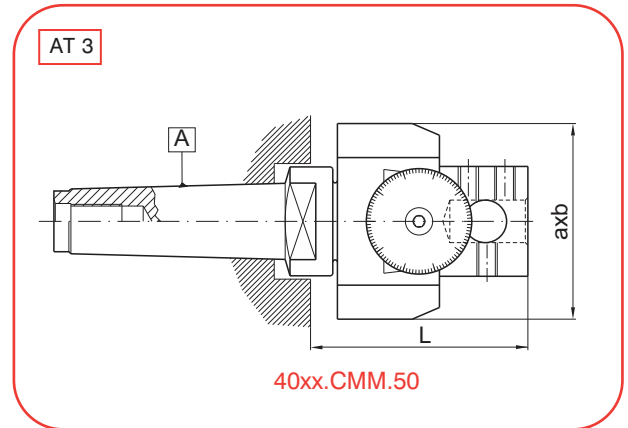

A	COD	d	L	a x b
04	3540.JCM.50	30-500	115	114 x 160
05	3540.JCM.50	30-500	115	114 x 160

A	COD	d	L	a x b
06	3550.JCM.50	30-500	115	114 x 160

accesorios - accessories

<ul style="list-style-type: none"> - 2 cuchillas K29-122 (REF: MM20801) - 2 cuchillas K29-82 (REF: MM20803) - 1 portacuchillas $\varnothing 25 \times 100$ cuadrado 8 (REF: MM15311) - 1 portacuchillas $\varnothing 25 \times 200$ cuadrado 8 (REF: MM15312) - 1 portacuchillas $\varnothing 40 \times 100$ cuadrado 12 (REF: MM15313) - 1 portacuchillas $\varnothing 40 \times 200$ cuadrado 12 (REF: MM15314) - 1 portamandrinos $\varnothing 25$ (REF: MM15315) - 1 juego de llaves allen 	<ul style="list-style-type: none"> - 2 tool bit K29-122 (REF: MM20801) - 2 tool bit K29-82 (REF: MM20803) - 1 toolholder $\varnothing 25 \times 100$ square 8 (REF: MM15311) - 1 toolholder $\varnothing 25 \times 200$ square 8 (REF: MM15312) - 1 toolholder $\varnothing 40 \times 100$ square 12 (REF: MM15313) - 1 toolholder $\varnothing 40 \times 200$ square 12 (REF: MM15314) - 1 toolholder adaptor $\varnothing 25$ (REF: MM15315) - 1 allen keys set
---	--

Piezas de recambio - Spare parts

A	REF.	REF.	REF.
04	4004.CMM.50	4004.CCM.50	CMM50
05	4005.CMM.50	4005.CCM.50	CMM50
06	4006.CMM.50	4006.CCM.50	CMM50