

Juego de cabezal de mandrinar micrométrico. DIN 2080

Set of micrometric boring head. DIN 2080



Utilización: Para mandrinar con precisión $\pm 0,01$ mm. y hasta $\varnothing 250$ mm.

Suministro: Un cabezal de mandrinar en un estuche de plástico + accesorios A, B ó C

Accesorios .A - Indicados abajo.

Accesorios .C - Indicados abajo.

Accesorios .B - Accesorios .A + .C

Application: For precision boring $\pm 0,01$ mm. and up to $\varnothing 250$ mm.

Delivery: One boring head in a plastic box + A, B or C accessories.

Accessories .A - Indicated below.

Accessories .C - Indicated below.

Accessories .B - Accessories .A + .C

35xx.JCM.25.x

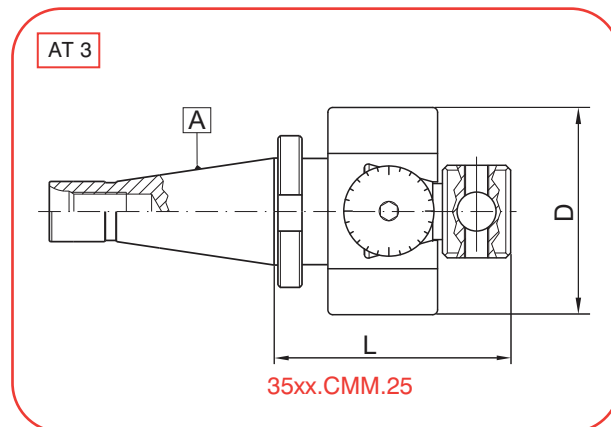

A	COD	d	L	D
30	3530.JCM.25.A	20-250	85	85
	3530.JCM.25.B			
	3530.JCM.25.C			
40	3540.JCM.25.A	20-250	85	85
	3540.JCM.25.B			
	3540.JCM.25.C			

A	COD	d	L	D
50	3550.JCM.25.A	20-250	85	85
	3550.JCM.25.B			
	3550.JCM.25.C			

accesorios .A - accessories .A

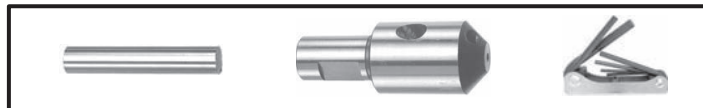

La opción .A contiene:

- 1 cuchilla de acero rápido de $\varnothing 6$ (REF: MM15401)
- 1 cuchilla de acero rápido de $\varnothing 8$ (REF: MM15402)
- 1 cuchilla de perfil constante de mango $\varnothing 10$ (REF: MM15403)
- 1 portacuchillas $\varnothing 10$ (REF: MM15301)
- 1 portacuchillas $\varnothing 8 \times 25 \times 20$ (REF: MM15302)
- 1 portacuchillas $\varnothing 8 \times 25 \times 40$ (REF: MM15303)
- 1 portacuchillas $\varnothing 6 \times 16 \times 75$ (REF: MM15304)
- 1 portacuchillas $\varnothing 8 \times 25 \times 75$ (REF: MM15305)
- 1 juego de llaves allen

La opción .C contiene:

- 1 portacuchillas $\varnothing 18 \times 16 \times 105$ con plaquita perdida CCMT060204
- 1 portacuchillas $\varnothing 28 \times 16 \times 105$ con plaquita perdida CCMT09T304

accesorios .C - accessories .C



Option A contains:

- 1 high speed steel tool bit $\varnothing 6$ (REF: MM15401)
- 1 high speed steel tool bit $\varnothing 8$ (REF: MM15402)
- 1 constant profile tool bit $\varnothing 10$ shank (REF: MM15403)
- 1 toolholder $\varnothing 10$ (REF: MM15301)
- 1 toolholder $\varnothing 8 \times 25 \times 20$ (REF: MM15302)
- 1 toolholder $\varnothing 8 \times 25 \times 40$ (REF: MM15303)
- 1 toolholder $\varnothing 6 \times 16 \times 75$ (REF: MM15304)
- 1 toolholder $\varnothing 8 \times 25 \times 75$ (REF: MM15305)
- 1 allen keys set

Option .C contains:

- 1 toolholder $\varnothing 18 \times 16 \times 105$ with carbide insert CCMT060204
- 1 toolholder $\varnothing 28 \times 16 \times 105$ with carbide insert CCMT09T304

Piezas de recambio - Spare parts

A	REF.	REF.	REF.
30	3530.CMM.25	3530.CCM.25	CMM25
40	3540.CMM.25	3540.CCM.25	CMM25
50	3550.CMM.25	3550.CCM.25	CMM25