

## Portafresas Weldon extracorto. DIN 2080

### Short weldon end mill holders. DIN 2080

**Utilización:** Para la sujeción de Herramientas con mango cilíndrico WELDON según DIN 1835-B + DIN 6535-HB ó mango cilíndrico Whistle-Notch según DIN 1835-E + DIN 6535-HE.

**Tolerancia Ød:** +0,007/0.

**Suministro:** Incluido los tornillos de sujeción

**Application:** For clamping WELDON cylindrical shank tools according to DIN 1835-B + DIN 6535-HB, or Whistle-Notch cylindrical shank according to DIN 1835-E + DIN 6535-HE.

**Tolerance Ød:** +0,007/0

**Delivery:** Tightening bolts included



# 35xx.WWC

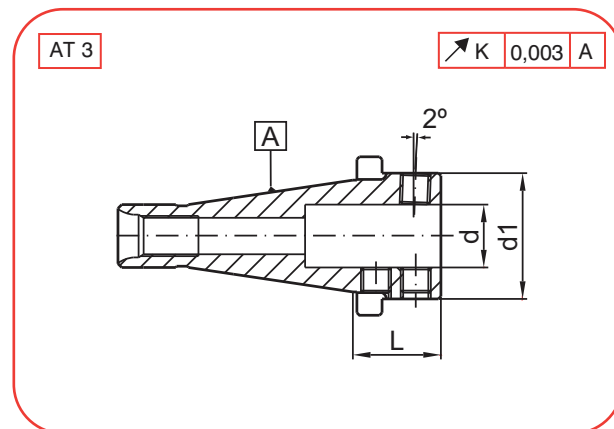
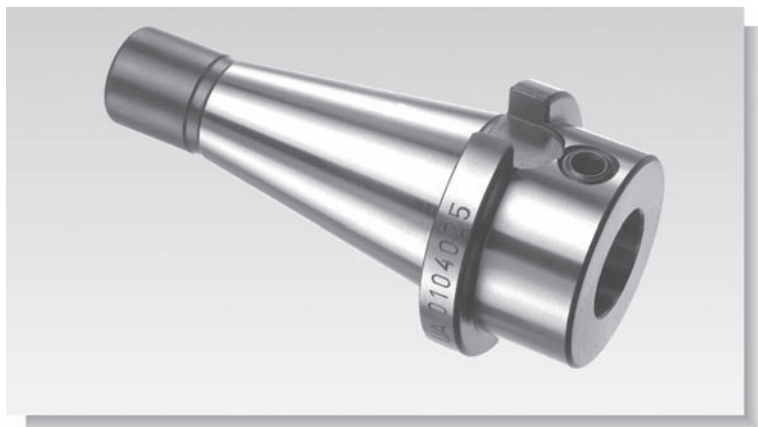

A	COD	d	L	d1
40	3540.WWC.25	25	35	50
	3540.WWC.32	32	45	60

A	COD	d	L	d1
50	3550.WWC.25	25	35	80
	3550.WWC.32	32	35	80
	3550.WWC.40	40	45	80

### Piezas de recambio - Spare parts

A = ISO40		A = ISO50	
d	REF.	d	REF.
25	T312012 (M12x12)	25	T312020 (M12x20)
32	T312012 (M12x12)	32	T312020 (M12x20)
		40	T312016 (M12x16)