

Portafresas Weldon. JIS B 6339 (BT) + DIN 69871-B**Weldon end mill holders. JIS B 6339 (BT) + DIN 69871-B**

Utilización: Para la sujeción de Herramientas con mango cilíndrico WELDON según DIN 1835-B

Tolerancia Ød: 6-18= +0,005/0 , 20-50= +0,007/0

Suministro: Incluido el tornillo de sujeción

Application: For clamping WELDON cylindrical shank tools according to DIN 1835-B

Tolerance Ød: 6-18= +0,005/0 , 20-50= +0,007/0

Delivery: Tightening bolt included

30xx.WEL
31xx.WEL

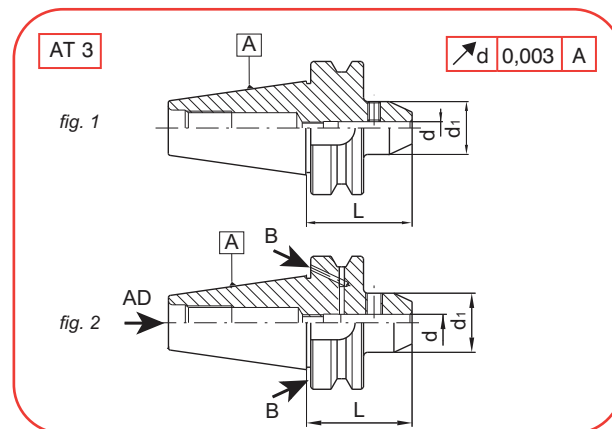
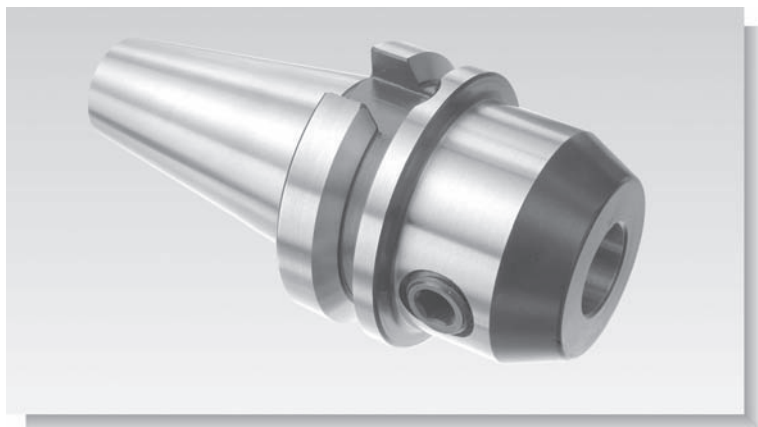

A	COD FORM AD (fig. 1)	COD FORM B (fig. 2)	d	L	d1
30	3030.WEL.06	-	6	50	25
	3030.WEL.08	-	8	50	28
	3030.WEL.10	-	10	50	35
	3030.WEL.12	-	12	50	42
	3030.WEL.16	-	16	63	48
	3030.WEL.20	-	20	63	52
40	3040.WEL.06	3140.WEL.06	6	50	25
	3040.WEL.08	3140.WEL.08	8	50	28
	3040.WEL.10	3140.WEL.10	10	63	35
	3040.WEL.12	3140.WEL.12	12	63	42
	3040.WEL.14	3140.WEL.14	14	63	44
	3040.WEL.16	3140.WEL.16	16	63	48
	3040.WEL.18	3140.WEL.18	18	63	50
	3040.WEL.20	3140.WEL.20	20	63	52
	3040.WEL.25	3140.WEL.25	25	90	65
	3040.WEL.32	3140.WEL.32	32	100	72

A	COD FORM AD (fig. 1)	COD FORM B (fig. 2)	d	L	d1
50	3050.WEL.06	3150.WEL.06	6	63	25
	3050.WEL.08	3150.WEL.08	8	63	28
	3050.WEL.10	3150.WEL.10	10	80	35
	3050.WEL.12	3150.WEL.12	12	80	42
	3050.WEL.14	3150.WEL.14	14	80	44
	3050.WEL.16	3150.WEL.16	16	80	48
	3050.WEL.18	3150.WEL.18	18	80	50
	3050.WEL.20	3150.WEL.20	20	80	52
	3050.WEL.25	3150.WEL.25	25	100	65
	3050.WEL.32	3150.WEL.32	32	105	72
3050.WEL.40	3150.WEL.40	40	110	80	

Piezas de recambio - Spare parts

FORM AD + FORM B



d	REF.	d	REF.
6	T306010 (M6x10)	18	T314016 (M14x16)
8	T308010 (M8x10)	20	T316016 (M16x16)
10	T310012 (M10x12)	25	T318020 (M18x20)
12	T312016 (M12x16)	32	T320020 (M20x20)
14	T312016 (M12x16)	40	T320020 (M20x20)
16	T314016 (M14x16)		