

Portafresas Weldon. DIN 69871-AD + B

Weldon end mill holders. DIN 69871-AD + B



Utilización: Para la sujeción de Herramientas con mango cilíndrico WELDON según DIN 1835-B

Tolerancia Ød: 6-18= +0,005/0 , 20-50= +0,007/0

Suministro: Incluido el tornillo de sujeción

Application: For clamping WELDON cylindrical shank tools according to DIN 1835-B

Tolerance Ød: 6-18= +0,005/0 , 20-50= +0,007/0

Delivery: Tightening bolt included

10xx.WEL
11xx.WEL

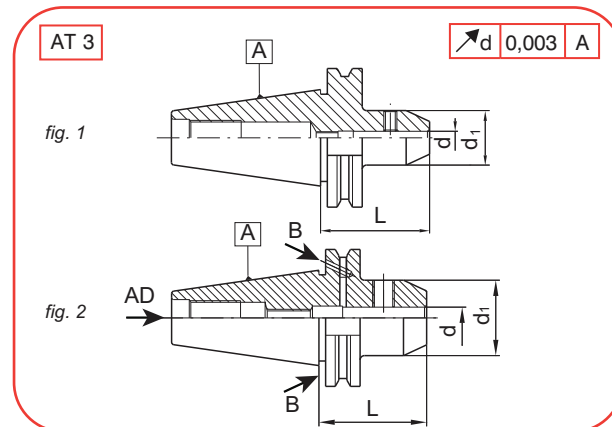

A	COD FORM AD (fig. 1)	COD FORM B (fig. 2)	d	L	d1
40	1040.WEL.06	1140.WEL.06	6	50	25
	1040.WEL.08	1140.WEL.08	8	50	28
	1040.WEL.10	1140.WEL.10	10	50	35
	1040.WEL.12	1140.WEL.12	12	50	42
	1040.WEL.14	1140.WEL.14	14	50	44
	1040.WEL.16	1140.WEL.16	16	63	48
	1040.WEL.18	1140.WEL.18	18	63	50
	1040.WEL.20	1140.WEL.20	20	63	52
	1040.WEL.25	1140.WEL.25	25	100	65
	1040.WEL.32	1140.WEL.32	32	100	72

A	COD FORM AD (fig. 1)	COD FORM B (fig. 2)	d	L	d1
50	1050.WEL.06	1150.WEL.06	6	50	25
	1050.WEL.08	1150.WEL.08	8	50	28
	1050.WEL.10	1150.WEL.10	10	50	35
	1050.WEL.12	1150.WEL.12	12	50	42
	1050.WEL.14	1150.WEL.14	14	50	44
	1050.WEL.16	1150.WEL.16	16	63	48
	1050.WEL.18	1150.WEL.18	18	63	50
	1050.WEL.20	1150.WEL.20	20	63	52
	1050.WEL.25	1150.WEL.25	25	100	65
	1050.WEL.32	1150.WEL.32	32	100	72
	1050.WEL.40	1150.WEL.40	40	100	80

Piezas de recambio - Spare parts

FORM AD + FORM B			
d	REF.	d	REF.
6	T306010 (M6x10)	18	T314016 (M14x16)
8	T308010 (M8x10)	20	T316016 (M16x16)
10	T310012 (M10x12)	25	T318020 (M18x20)
12	T312016 (M12x16)	32	T320020 (M20x20)
14	T312016 (M12x16)	40	T320020 (M20x20)
16	T314016 (M14x16)		