

Mandrilos para platos de fresar con guía. DIN 69871-A

Face mill adaptors. DIN 69871-A

Utilización: Para platos de fresar.

Tolerancia Ød: g5.

Suministro: Incluidos los tetones de arrastre y el tornillo de sujeción.

Application: For indexable milling cutters.

Tolerance Ød: g5.

Delivery: Driving keys and tightening bolt are included.



10xx.PPG

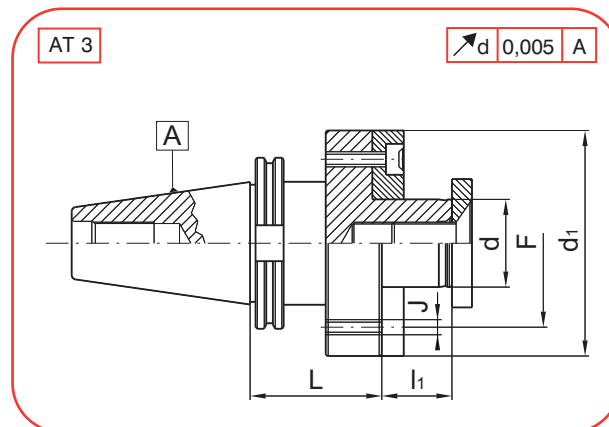

A	COD	d	L	d1	l1	F	J
40	1040.PPG.40	40	55	88,882	30	66,7	M12
50	1050.PPG.40	40	75	88,882	30	66,7	M12
	1050.PPG.50	50	75	125,57	40	101,6	M16
	1050.PPG.60	60	75	125,57	40	101,6	M16

Piezas de recambio - Spare parts

d	REF.	REF.	REF.	REF.
40	AMF40	T120040 (M20x40)	CHI40	T206015 (M6x15)
50	AMF50	T124050 (M24x50)	CHI50	T212025 (M12x25)
60	AMF60	T130055 (M30x55)	CHI50	T212025 (M12x25)