

## Juego de cabezal de mandrinar micrométrico. DIN 2080

### Set of micrometric boring head. DIN 2080

**Utilización:** Para mandrinar con precisión  $\pm 0,01$  mm. y hasta  $\varnothing 500$  mm.

**Suministro:** Un cabezal de mandrinar en un estuche de plástico + accesorios indicados abajo

**Application:** For precision boring  $\pm 0,01$  mm. and up to  $\varnothing 500$  mm.

**Delivery:** One boring head in a plastic box + A, B or C accessories indicated below.



# 35xx.JCM.50

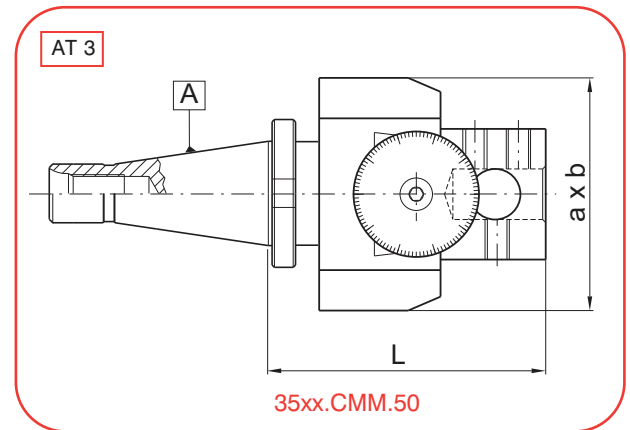



A	COD	d	L	a x b
40	3540.JCM.50	30-500	140	114 x 160

A	COD	d	L	a x b
50	3550.JCM.50	30-500	140	114 x 160

#### accesorios - accessories

   	<ul style="list-style-type: none"> <li>- 2 cuchillas K29-122 (REF: MM20801)</li> <li>- 2 cuchillas K29-82 (REF: MM20803)</li> <li>- 1 portacuchillas <math>\varnothing 25 \times 100</math> cuadrado 8 (REF: MM15311)</li> <li>- 1 portacuchillas <math>\varnothing 25 \times 200</math> cuadrado 8 (REF: MM15312)</li> <li>- 1 portacuchillas <math>\varnothing 40 \times 100</math> cuadrado 12 (REF: MM15313)</li> <li>- 1 portacuchillas <math>\varnothing 40 \times 200</math> cuadrado 12 (REF: MM15314)</li> <li>- 1 portamandrilos <math>\varnothing 25</math> (REF: MM15315)</li> <li>- 1 juego de llaves allen</li> </ul>	<ul style="list-style-type: none"> <li>- 2 tool bit K29-122 (REF: MM20801)</li> <li>- 2 tool bit K29-82 (REF: MM20803)</li> <li>- 1 toolholder <math>\varnothing 25 \times 100</math> square 8 (REF: MM15311)</li> <li>- 1 toolholder <math>\varnothing 25 \times 200</math> square 8 (REF: MM15312)</li> <li>- 1 toolholder <math>\varnothing 40 \times 100</math> square 12 (REF: MM15313)</li> <li>- 1 toolholder <math>\varnothing 40 \times 200</math> square 12 (REF: MM15314)</li> <li>- 1 toolholder adaptor <math>\varnothing 25</math> (REF: MM15315)</li> <li>- 1 allen keys set</li> </ul>
---	---	--

#### Piezas de recambio - Spare parts

			
A	REF.	REF.	REF.
40	3540.CMM.50	3540.CCM.50	CMM50
50	3550.CMM.50	3550.CCM.50	CMM50