

Portafresas combinado. DIN 69871-A**Combi shell mill adaptors. DIN 69871-A**

Utilización: Para sujeción de fresas frontales DIN841 y DIN1880, fresas frontales cónicas DIN842 y platos de fresar DIN1830.

Tolerancia Ød: h6.

Suministro: Incluidos el anillo de arrastre, la chaveta longitudinal y el tornillo de sujeción.

Application: For clamping shell end mills DIN841 and DIN1880, angular milling cutters DIN842 and indexable cutters DIN1830.

Tolerance Ød: h6

Delivery: Tightening bolt, diving ring and feather key are included.

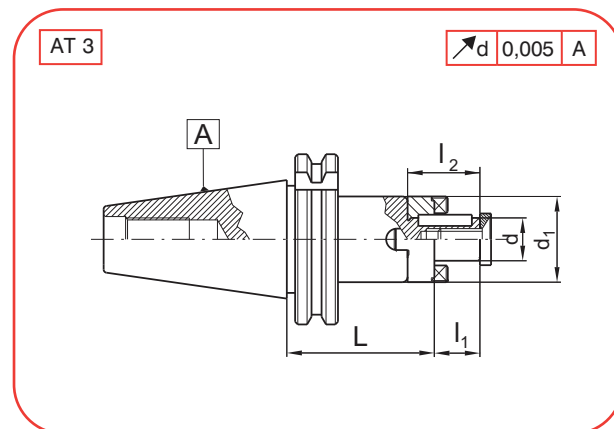
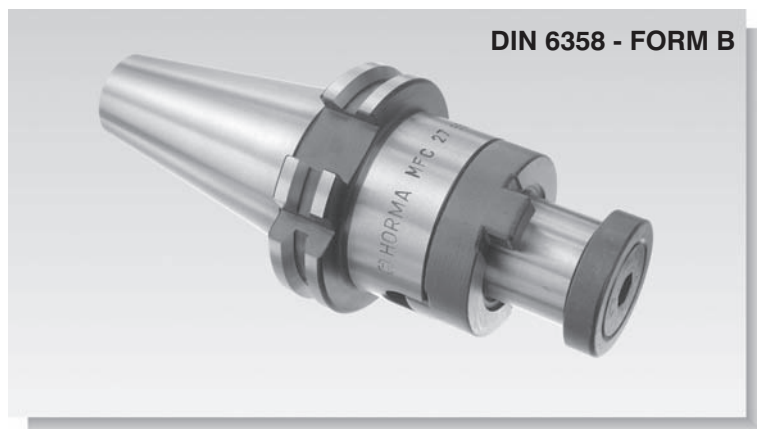
10xx.MFC

A	COD	d	L	d1	l1	l2
40	1040.MFC.16	16	55	32	17	27
	1040.MFC.22	22	55	40	19	31
	1040.MFC.27	27	55	48	21	33
	1040.MFC.32	32	60	58	24	38
	1040.MFC.40	40	60	70	27	41

A	COD	d	L	d1	l1	l2
50	1050.MFC.16	16	55	32	17	27
	1050.MFC.22	22	55	40	19	31
	1050.MFC.27	27	55	48	21	33
	1050.MFC.32	32	55	58	24	38
	1050.MFC.40	40	55	70	27	41

Piezas de recambio - Spare parts

d	REF.	REF.	REF.	REF.
16	AMF16	T108020 (M8x20)	AMC16	CHL0404020 (4x4x20)
22	AMF22	T110025 (M10x25)	AMC22	CHL0606025 (6x6x25)
27	AMF27	T112025 (M12x25)	AMC27	CHL0707025 (7x7x25)
32	AMF32	T116035 (M16x35)	AMC32	CHL0807028 (8x7x28)
40	AMF40	T120040 (M20x40)	AMC40	CHL1008032 (10x8x32)