

## Reductores para cono ISO. DIN 69871-AD

### ISO Taper adaptors. DIN 69871-AD

**Utilización:** Para herramientas con cono ISO según DIN2080.

**Suministro:** El tornillo o el tirante alargado se deben pedir separadamente.

**Application:** For holding tools with ISO taper according to DIN2080.

**Delivery:** The screw DIN912 or the long pull stud have to be ordered separately.



# 10xx.RTI

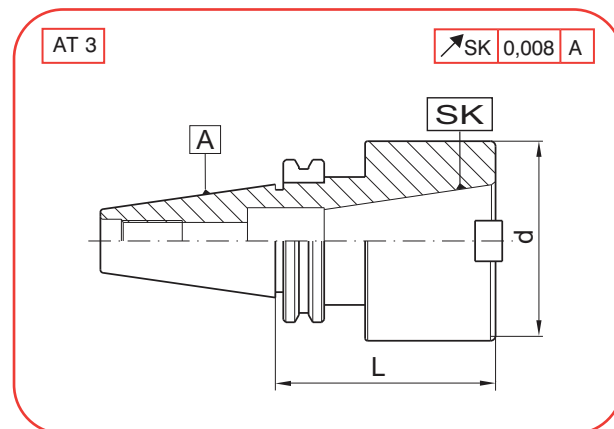
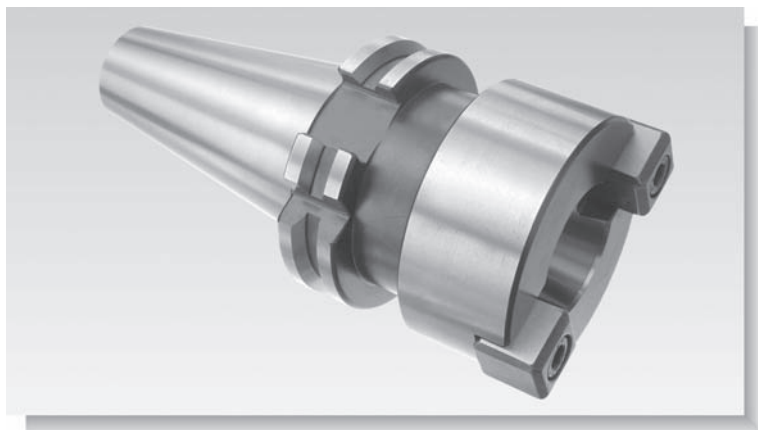

A	SK	COD	L	d
40	ISO30	1040.RTI.30	63	63
	ISO40	1040.RTI.40	86	78

A	SK	COD	L	d
50	ISO40	1050.RTI.40	60	80

En los conos de tamaño A=40, la sujeción de la herramienta se realiza por medio de tirante largo, mientras que en los conos de tamaño A=50 se usan tornillos allen.

*With taper A=40, tools are always held with long pull studs while with taper A=50 DIN912 screws are used.*

### Piezas de recambio - Spare parts

A = 40			A = 50			
SK	REF.	REF.	SK	REF.	REF.	
ISO30	CHI40	T206015	ISO30	TIL4012100	TIL4012200	
ISO40	CHI50	T206015	ISO40	TIL4016100	TIL4016200	
					ISO40	T216035