



3

**MASCHINEN- UND WERKBANKSCHRAUBSTÖCKE
VISES**

MASCHINEN- UND WERKBANKSCHRAUBSTÖCKE

VICES

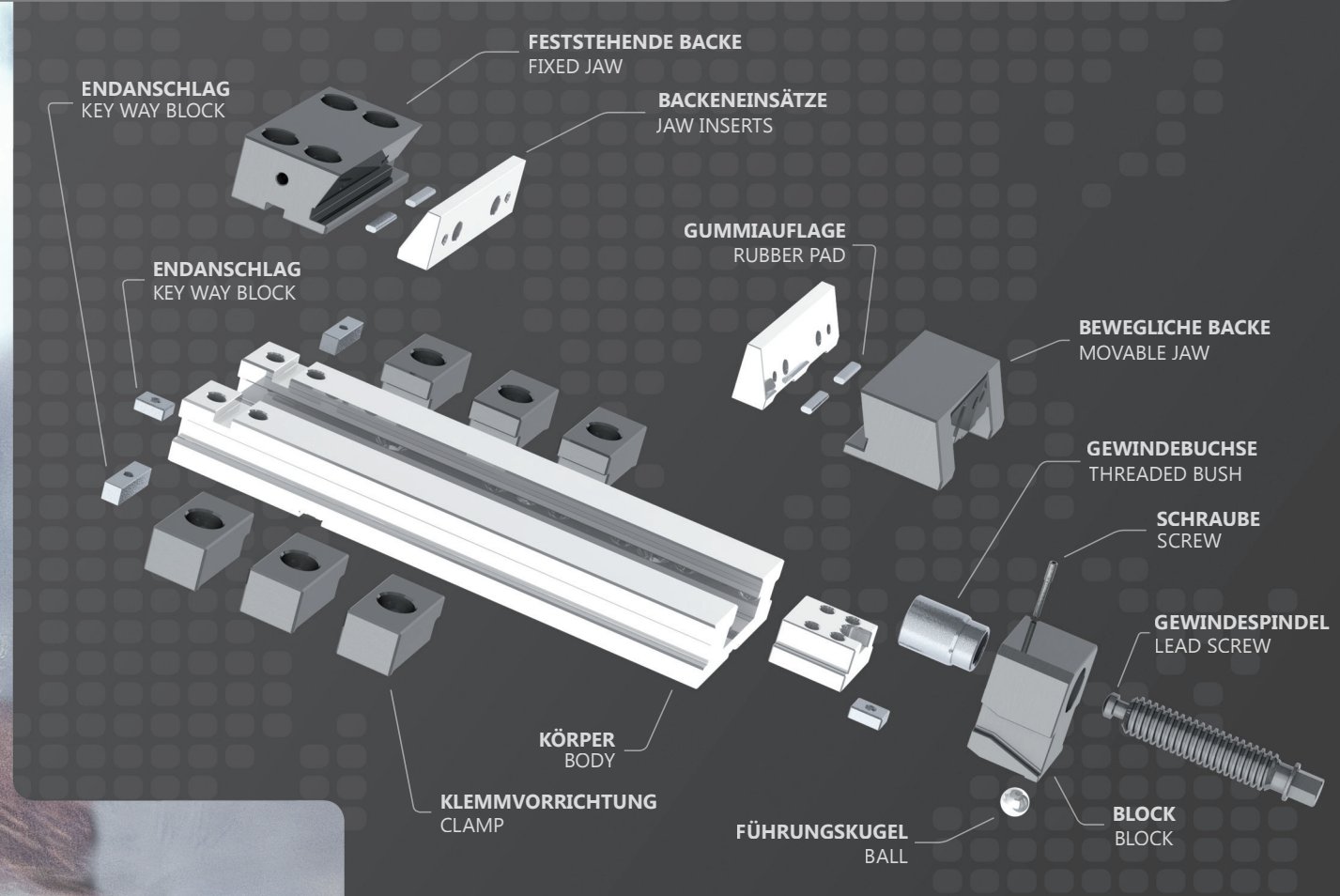
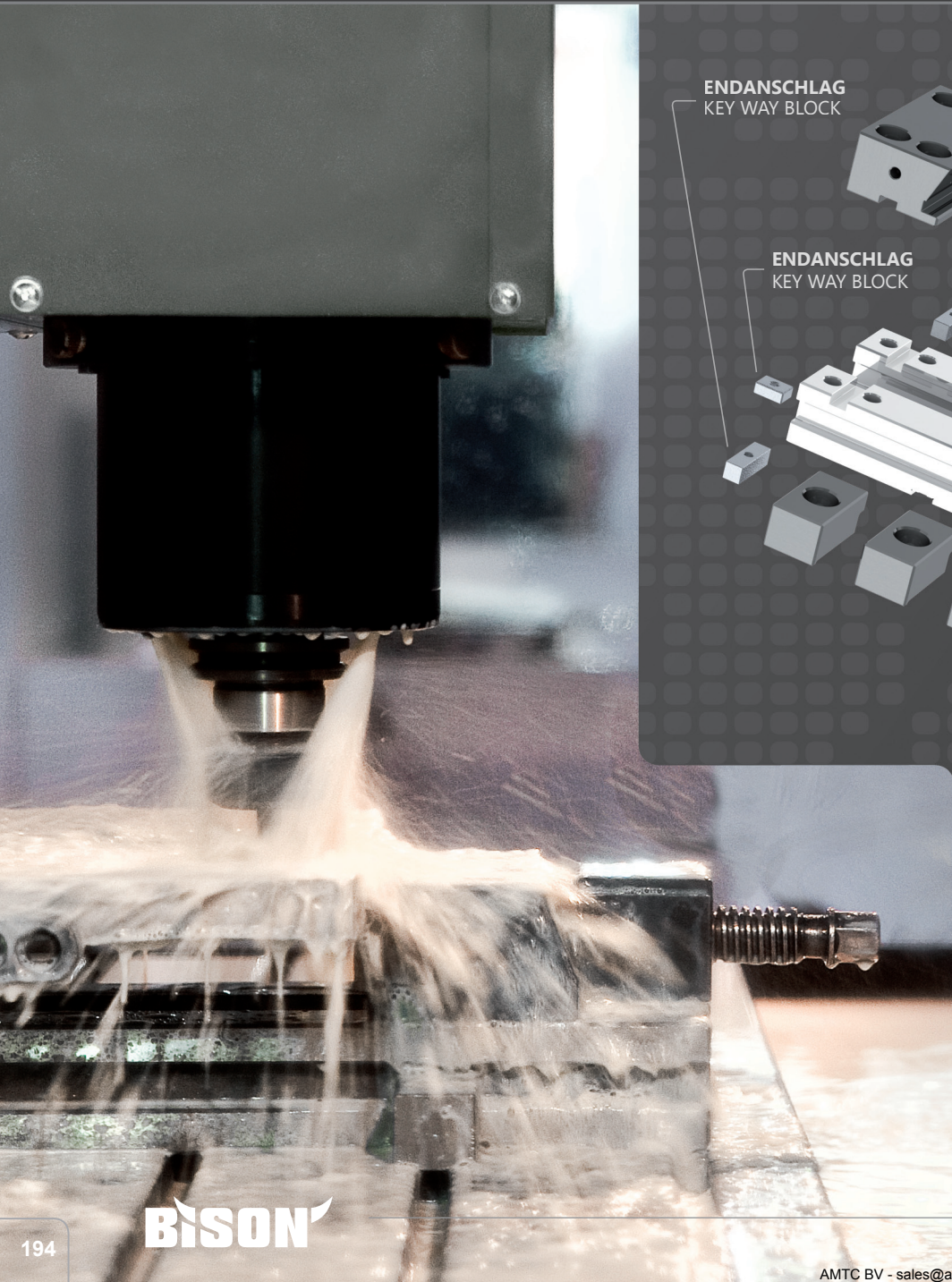

BISON bietet Ihnen ein umfangreiches Schraubstock-Sortiment. Sparen Sie Zeit und Geld in Ihrem Arbeitsalltag durch unsere anwenderfreundlichen Produkte!

BISON offers an extensive range of vises. Save time and money in your daily work by our user-friendly products!



I PRÄZISIONSSCHRAUBSTÖCKE PRECISION VISES 196-202

TYP TYPE	BESCHREIBUNG DESCRIPTION	SEITE PAGE
6620	PRÄZISIONSSCHRAUBSTÖCKE PRECISION VISES	196
6621	PRÄZISIONSSCHRAUBSTÖCKE • MIT HYDRAULISCHER SPINDEL PRECISION VISES • WITH HYDRAULIC SPINDLE	197
6820	PRÄZISIONSSCHRAUBSTÖCKE • NC PRECISION VISES • NC	198
6821	PRÄZISIONSSCHRAUBSTÖCKE • NC MIT HYDRAULISCHER SPINDEL PRECISION VISES • NC WITH HYDRAULIC SPINDLE	199
6632	PRÄZISIONSSCHRAUBSTÖCKE • PRÄZISIONS-DOPPELSPANNER PRECISION VISES • DOUBLE CLAMPING	200
6622	MODULAR-SCHRAUBSTÖCKE • BEWEGLICHES ELEMENT MODULES • MOVABLE ELEMENT	201
6623	MODULAR-SCHRAUBSTÖCKE • BEWEGLICHES ELEMENT MIT HYDRAULIKSPINDEL MODULES • MOVABLE ELEMENT WITH HYDRAULIC SPINDLE	201
6624	MODULAR-SCHRAUBSTÖCKE • FIXES ELEMENT MODULES • FIXED ELEMENT	201
6850	PRÄZISIONSSCHRAUBSTÖCKE • MEHRFACHSPANNERL PRECISION VISES • MODULAR CLAMPING SYSTEM	202
6851	PRÄZISIONSSCHRAUBSTÖCKE • MEHRFACHSPANNER PRECISION VISES • MODULAR CLAMPING SYSTEM	202
6852	PRÄZISIONSSCHRAUBSTÖCKE • MEHRFACHSPANNER PRECISION VISES • MODULAR CLAMPING SYSTEM	202

II MASCHINENSCHRAUBSTÖCKE MACHINE VISES 203-212

TYP TYPE	BESCHREIBUNG DESCRIPTION	SEITE PAGE
6710	PNEUMATISCH BETÄTIGT PNEUMATICALLY OPERATED	203
6512	MIT BEWEGLICHER BACKE WITH MOVABLE REAR JAW	204
6516	MIT HYDRAULISCHER SPINDEL WITH HYDRAULIC SPINDLE	205
6517	MIT ABSCHNITTSWEISER SCHNELLVERSTELLUNG CAMLOCK	206
6522	GETEILTEN SCHRAUBSTOCK TWO-PIECE	207
6523	MIT HOHER HALTEKRAFT HOLD-TIGHT	208
6530	NEIG- UND DREHBAR SWIVEL OF TWO ANGLE	209
6531	SELBSTZENTRIEREND SELF-CENTERING	209
6534	DREH-, NEIG- UND SCHWENKBAR THREE ANGLE MULTI-PURPOSE	210
6540	MIT SCHNELLVERSTELLUNG, KONTINUIERLICH QUICK ACTING	210
6542	MIT SCHNELLVERSTELLUNG, KONTINUIERLICH QUICK ACTING • DRILLING	211
6543	BOHRMASCHINEN-SCHRAUBSTOCK DRILLING	211
6546	WELLEN-SCHRAUBSTOCK SHAFT HOLDING	212
6910	MIT PRISMATISCHER BACKENFÜHRUNG WITH PRISMATIC GUIDANCE OF MOVABLE JAW	212

III WERKZEUGMACHER- UND PRÜFSCHRAUBSTÖCKE TOOLMAKER'S & INSPECTION VISES 213-214

TYP TYPE	BESCHREIBUNG DESCRIPTION	SEITE PAGE
6552	WM-SCHRAUBSTOCK MIT GLATTEN BACKEN PLAIN	213
6553	WM-SCHRAUBSTOCK MIT PRISMATISCHEN BACKEN WITH VERTICAL PRISM	213
6554	SINUS-SCHRAUBSTOCK MIT BEWEGLICHER QUERACHSE SINE VISE WITH FRONT SWIVELLING AXIS	214
6555	SINUS-SCHRAUBSTOCK MIT BEWEGLICHER LÄNGSACHSE SINE VISE WITH LONGITUDINAL SWIVELLING AXIS	214

IV WERKBANK-SCHRAUBSTÖCKE BENCH VISES 215-218

TYP TYPE	BESCHREIBUNG DESCRIPTION	SEITE PAGE
1240	SCHWERLAST-SCHRAUBSTOCK HEAVY DUTY TABLE	215
1250	SCHRAUBSTOCK HEAVY DUTY	215
1253	SCHMIEDE-SCHRAUBSTOCK BLACKSMITH'S	216
1256	MOBILER SCHRAUBSTOCK, DREHBAR PORTABLE WITH SWIVEL BASE	216
1710	ROHR-SCHRAUBSTOCK FOR PIPES	217
1711	DREIBEINSTATIV FÜR ROHR-SCHRAUBSTOCK TRIPOD FOR PIPE VISES	217
1271	SCHWERLAST-SCHRAUBSTOCK, MULTI-AXIAL BEWEGLICH ALL AXIS	218

V MANUELL BETÄTIGTE PRESSE PRESSES 219

TYP TYPE	BESCHREIBUNG DESCRIPTION	SEITE PAGE
9210	MANUELL BETÄTIGTE PRESSE MANUALLY OPERATED	219

VI ZUBEHÖR UND ERSATZTEILE SPARE PARTS & ACCESSORIES 220-232

VII TECHNISCHE DATEN TECHNICAL DATA 233-234

6620

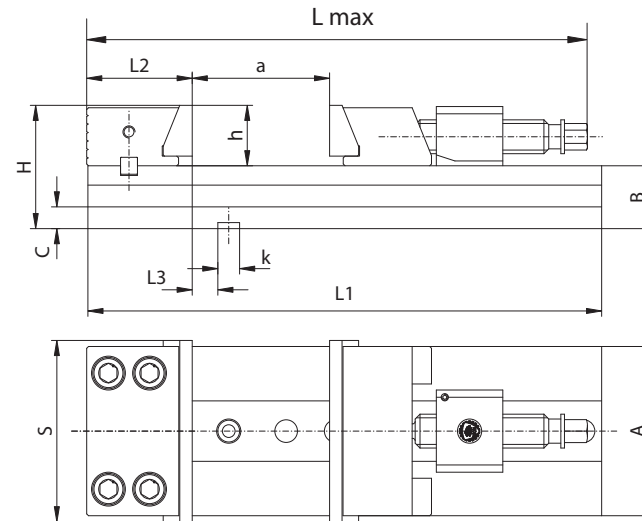
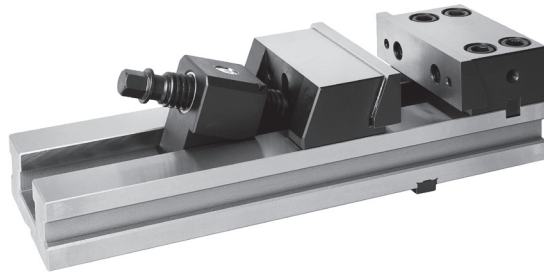

Eigenschaften:

- Optimiertes und verbessertes Nachfolgemodell des Typs 6577
- Umkehrbare fixe Backe, schnell nachstellbare, selbst-regulierende bewegliche Backe
- Auswechselbare Backeneinsätze
- In Verbindung mit Drehplatte einsetzbar
- Hochlegierter Qualitätsstahl, stabilisiert und gehärtet

Anwendung:

- Entworfen für präzise Schleif- und Fräsarbeiten

Standardzubehör:

- Schlüssel
- Nutensteine mit „k“ Maß
- Schraubstock-Halterungen
- Schwenkbare Backenaufsätze

Features:

- Revised and upgraded successor model of Type 6577
- Reversible fixed jaw
- Quick re-adjustable, self-adjusting movable jaws
- Can be used with removable jaw inserts
- Made of high-grade alloy steel, stabilized and hardened

Application:

- Designed for precision grinding and milling

Standard accessories:

- Wrench
- Slot nuts with „k“ dimension
- Vise clamps
- Swinging lead plate

Artikel Nr.	Typ	S	A	B -0,02	C	H	L max.	L1	L2	L3	a	h	k	Max. Spannkraft [daN] Max. clamping force [daN]	kg
Code No.	Type														
326620010600	6620-100-320-165	100	85	35	13	65	389	320	61,80	12,00	165	30	12	2.000	9,84
326620030000	6620-125-335-165	125	105	42	15	82	406	335	68,00	18,00	165	40	12	3.000	15,71
326620050300	6620-150-425-210	150	140	52	18	102	515	425	87,29	21,20	210	50	18	4.100	31,95
326620060500	6620-150-475-260	150	140	52	18	102	565	475	87,29	21,20	260	50	18	4.100	35,18
326620070700	6620-150-520-305	150	140	52	18	102	610	520	87,29	21,20	305	50	18	4.100	36,96
326620100500	6620-200-535-260	200	165	61	20	121	623	535	109,43	38,07	260	60	18	4.500	58,95
326620110700	6620-200-585-310	200	165	61	20	121	673	585	109,43	38,07	310	60	18	4.500	61,66
326620120900	6620-200-635-360	200	165	61	20	121	723	635	109,43	38,07	360	60	18	4.500	64,36

Zubehör • Accessories 220-232

Technische Daten • Technical Data 233-234

6621

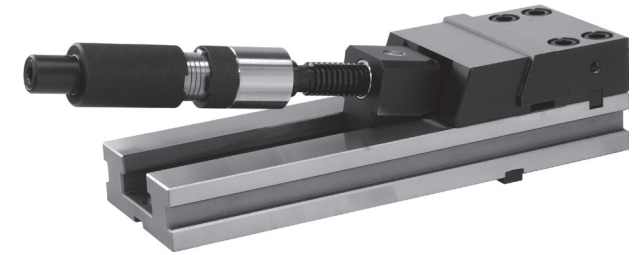

Eigenschaften:

- Optimiertes und verbessertes Nachfolgemodell des Typs 6578
- In Verbindung mit der hydraulischen Spindel ist durch hohe Spannkraft eine sichere Spannung bei geringem Kraftaufwand für den Anwender gewährleistet.
- Umkehrbare fixe Backe, schnell nachstellbare, selbst-regulierende bewegliche Backe
- Auswechselbare Backeneinsätze
- Hochlegierter Qualitätsstahl, stabilisiert und gehärtet

Anwendung:

- Entworfen für präzise Schleif- und Fräsarbeiten

Standardzubehör:

- Schlüssel
- Nutensteine mit „k“ Maß
- Schraubstock-Halterungen
- Schwenkbare Backenaufsätze

Features:

- Optimized and improved successor of the type 6578
- Vise equipped with hydraulic spindle enabling the application of high clamping force and safe clamping with little effort from the operator
- Reversible fixed jaw
- Quick re-adjustable, self-adjusting movable jaws
- Can be used with removable jaw inserts
- Made of high-grade alloy steel, stabilized and hardened

Application:

- Designed for precision grinding and milling

Standard accessories:

- Wrench
- Slot nuts with „k“ dimension
- Vise clamps
- Swinging lead plate

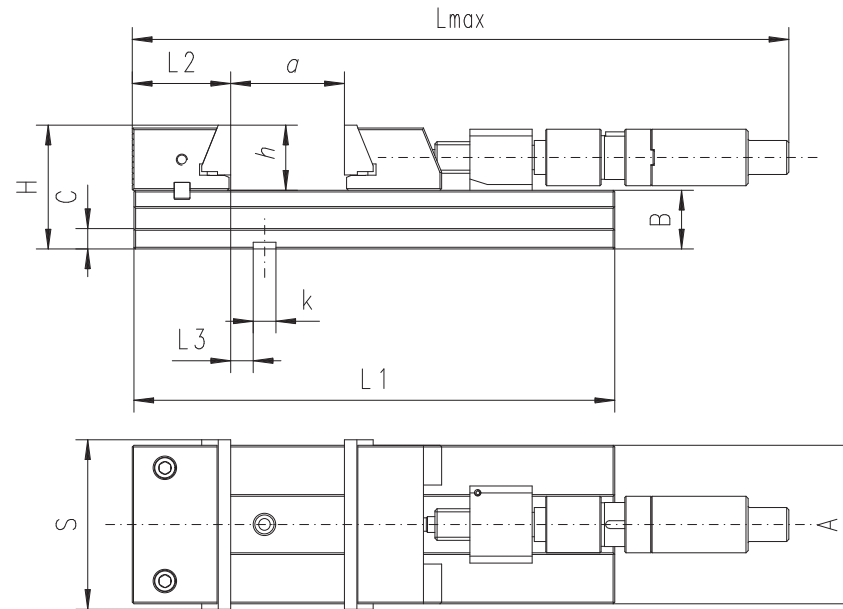

Artikel Nr.	Typ	S	A	B -0,02	C	H	L max.	L1	L2	L3	a	h	k	Max. Spannkraft [daN]	kg
Code No.	Type													Max. clamping force [daN]	
326621050100	6621-150-425-210	150	140	52	18	102	726	425	87,29	21,20	210	50	18	4.100	33,4
326621060300	6621-150-475-260	150	140	52	18	102	776	475	87,29	21,20	260	50	18	4.100	36,6
326621070500	6621-150-520-305	150	140	52	18	102	821	520	87,29	21,20	305	50	18	4.100	38,4
326621100300	6621-200-535-260	200	165	61	20	121	875	535	109,43	38,07	260	60	18	4.500	61,5
326621110500	6621-200-585-310	200	165	61	20	121	907	585	109,43	38,07	310	60	18	4.500	64,2
326621120700	6621-200-635-360	200	165	61	20	121	957	635	109,43	38,07	360	60	18	4.500	66,9

Zubehör • Accessories 220-232
Technische Daten • Technical Data 233-234

- 1
- 2
- 3
- 4
- 5
- 6
- 7

6621

6820

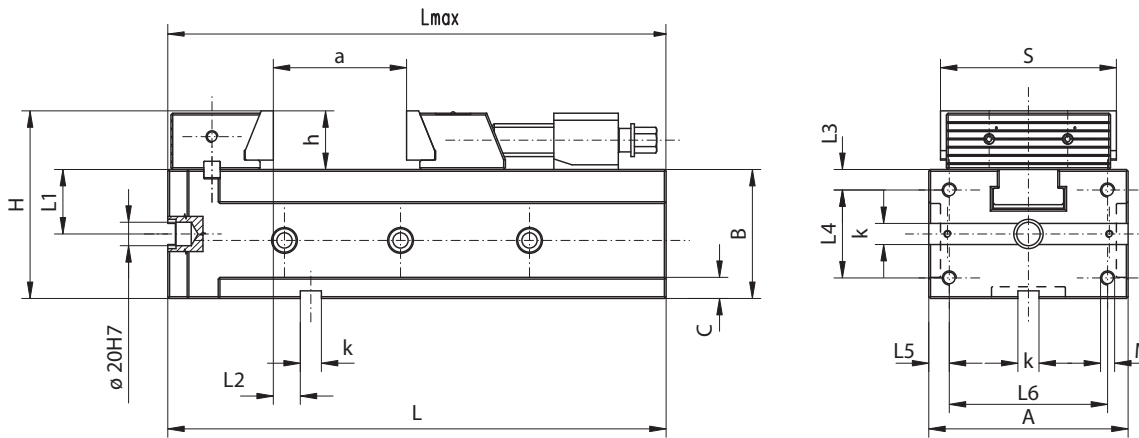
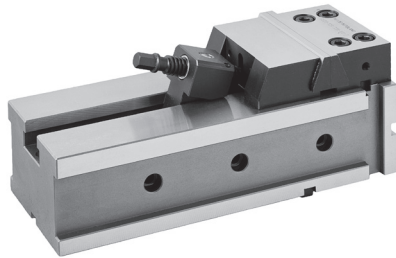

Artikel Nr.	Typ	S	A	a	B -0,02	C	H	h	K	L max.	L	L1 -0,02	L2 ±0,02	L3 ±0,1	L4 ±0,1	L5 ±0,1	L6 ±0,1	M	Max. Spannkraft [daN] Max. clamping force [daN]	kg
Code No.	Type																			
326820010900	6820-100-320-160	100	110	160	75	13	105	30	12	390	320	37,5	14	10	55	15	80	M10	2.000	19,2
326820020000	6820-125-335-160	125	130	160	90	15	130	40	12	406	335	45	19	15	55	17	96	M12	3.000	31,2
326820030200	6820-150-425-205	150	170	205	110	18	160	50	18	515	425	55	23	17,5	75	17,5	135	M12	4.100	63,4

Eigenschaften:

- Optimiertes und verbessertes Nachfolgemodell des Typs 6800
- Set von 4 Schraubstöcken kann vertikal genutzt werden
- Anbringung horizontal, vertikal oder liegend möglich
- Umkehrbare fixe Backe, schnell nachstellbare, selbst-regulierende bewegliche Backe
- Auswechselbare Backeneinsätze
- Hochlegierter Qualitätsstahl, stabilisiert und gehärtet

Anwendung:

- Entworfen für präzise Schleif- und Fräsarbeiten

Standardzubehör:

- Schlüssel
- Nutensteine mit „k“ Maß
- Schraubstock-Halterungen
- Schwenkbare Backenaufsätze

Features:

- Revised and upgraded successor model of Type 6800
- Horizontal, vertical or side mounting
- Set of 4 vises can be used vertically
- Reversible fixed jaw
- Quick re-adjustable, self-adjusting movable jaws
- Can be used with removable jaw inserts
- Made of high-grade alloy steel, stabilized and hardened

Application:

- Designed for precision grinding and milling

Standard accessories:

- Wrench
- Slot nuts with „k“ dimension
- Vise clamps
- Swinging lead plate

Zubehör • Accessories 220-232

Technische Daten • Technical Data 233-234

6821

Eigenschaften:

- Optimiertes und verbessertes Nachfolgemodell des Typs 6801
- Set von 4 Schraubstöcken kann vertikal genutzt werden
- Anbringung horizontal, vertikal oder liegend möglich
- Umkehrbare fixe Backe, schnell nachstellbare, selbst-regulierende bewegliche Backe
- Auswechselbare Backeneinsätze
- Hochlegierter Qualitätsstahl, stabilisiert und gehärtet

Anwendung:

- Entworfen für präzise Schleif- und Fräsarbeiten

Standardzubehör:

- Schlüssel
- Nutensteine mit „k“ Maß
- Schraubstock-Halterungen
- Schwenkbare Backenaufsätze

Features:

- Revised and upgraded successor model of Type 6801
- Vise equipped with hydraulic spindle enabling the application of high clamping force and safe clamping with little effort from the operator
- Horizontal, vertical or side mounting
- Set of 4 vises can be used vertically
- Reversible fixed jaw
- Quick re-adjustable, self-adjusting movable jaws
- Can be used with removable jaw inserts
- Made of high-grade alloy steel, stabilized and hardened

Application:

- Designed for precision grinding and milling

Standard accessories:

- Wrench
- Slot nuts with "k" dimension
- Vise clamps
- Swinging lead plate

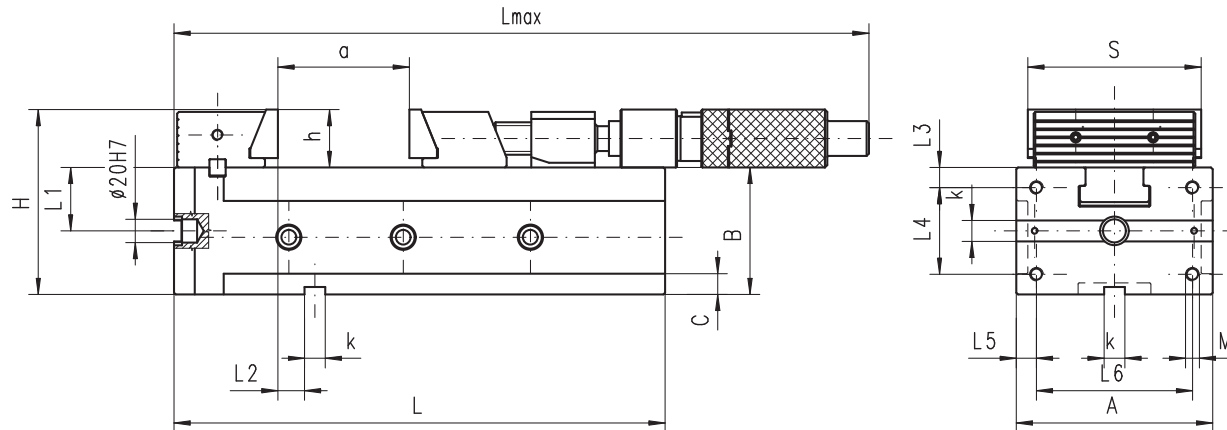
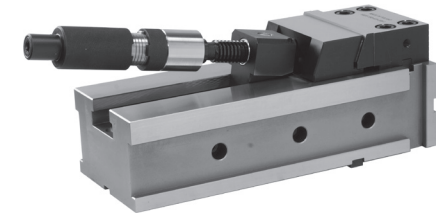

Zubehör • Accessories 220-232
Technische Daten • Technical Data 233-234

Artikel Nr.	Typ	S	A	a	B -0,02	C	H	h	K	L max.	L	L1 -0,02	L2 ±0,02	L3 ±0,1	L4 ±0,1	L5 ±0,1	L6 ±0,1	M	Max. Spannkraft [daN]	kg
Code No.	Type																		Max. clamping force [daN]	
326821030000	6821-150-425-205	150	170	205	110	18	160	50	18	726	425	55	23	17,5	75	17,5	135	M12	4.100	64,8

- 1
- 2
- 3
- 4
- 5
- 6
- 7

6821

6632

PRÄZISIONS-DOPPELSPANNER
DOUBLE CLAMPING

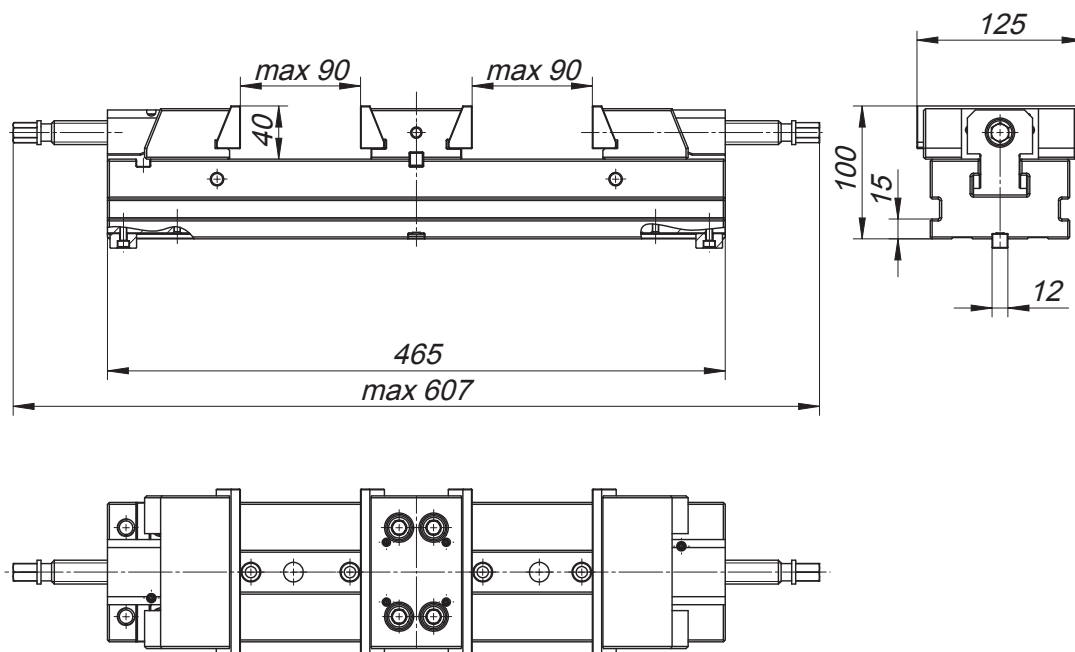
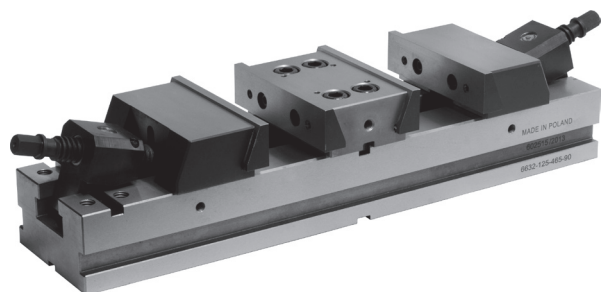

Eigenschaften:

- Umkehrbare fixe Backe, schnell nachstellbare, selbst-regulierende bewegliche Backe
- Hochlegierter Qualitätsstahl, stabilisiert und gehärtet, (58-62HRC) gewährleistet hohe Körpersteifigkeit
- Auswechselbare Backeneinsätze

Eigenschaften:

- Entworfen für präzise Schleif- und Fräsarbeiten

Standardzubehör:

- Schlüssel
- Nutensteine mit „k“ Maß
- Schraubstock-Halterungen
- Schwenkbare Backenaufsätze

Features:

- Reversible fixed jaw
- Quick re-adjustable, self-adjusting movable jaws
- Can be used with removable jaw inserts
- Made of high-grade alloy steel, stabilized and hardened

Application:

- Designed for precision grinding and milling

Standard accessories:

- Wrench
- Slots nuts with „k“ dimension
- Vise clamps
- Swinging lead plate

Artikel Nr.	Typ	Max. Spannkraft [daN]	kg
Code No.	Type	Max. clamping force [daN]	
326632020100	6632-125-465-90	3.000	27,5

Zubehör • Accessories 220-232

Technische Daten • Technical Data 233-234

1
2
3
4
5
6
7

6632

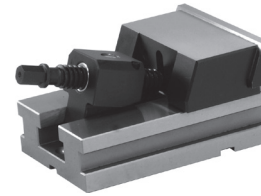
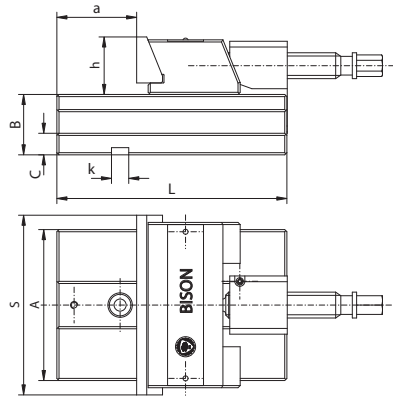

- Optimiertes und verbessertes Nachfolgemodell des Typs 6568
- Bewegliches Element
- Revised and upgraded successor model of Type 6568
- Movable element

6622

Zubehör • Accessories 220-232
Technische Daten • Technical Data 233-234

Artikel Nr. Code No.	Typ Type	S	A	B	C	L	a	h	k	Max. Spannkraft [daN] Max. clamping force [daN]	kg
326622010200	6622-100	100	85	35	13	140	48	30	12	2.000	5,3
326622020400	6622-125	125	105	42	15	160	60	40	12	3.000	8,7
326622030600	6622-150	150	140	52	18	210	86	50	18	4.100	20,6
326622040800	6622-200	200	165	61	20	240	78	60	18	4.500	34,3

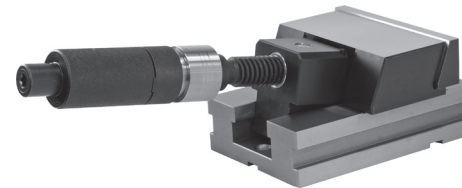
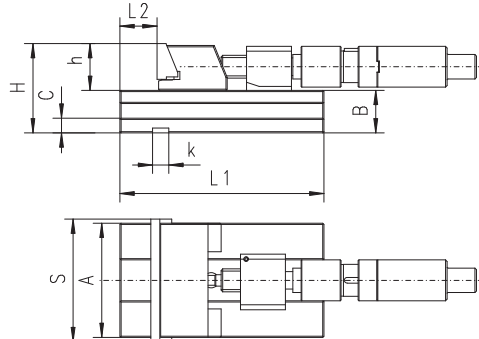

- Optimiertes und verbessertes Nachfolgemodell des Typs 6571
- Bewegliches Element mit hydraulischer Spindel
- Auf die gleiche Weise konstruiert wie Typ 6622
- Revised and upgraded successor model of Type 6571
- Movable element with hydraulic spindle
- Similar to Type 6622

6623

Zubehör • Accessories 220-232
Technische Daten • Technical Data 233-234

Artikel Nr. Code No.	Typ Type	S	A	B	C	H	L1	L2	h	k	Max. Spannkraft [daN] Max. clamping force [daN]	kg
326623030400	6623-150	150	140	52	18	102	210	86	50	18	4.100	20,6
326623040600	6623-200	200	165	61	20	121	240	78	60	18	4.500	34,3

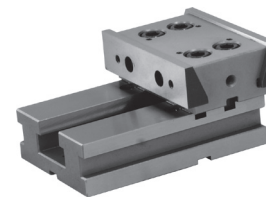
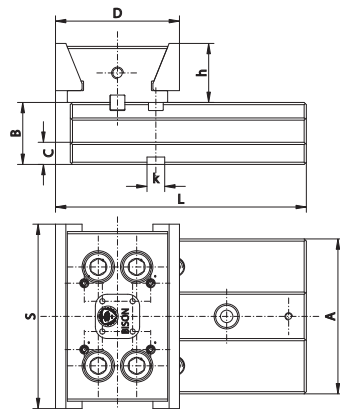

- Optimiertes und verbessertes Nachfolgemodell des Typs 6569-M
- Fixes Element
- Revised and upgraded successor model of Type 6569-M
- Fixed element

6624

Zubehör • Accessories 220-232
Technische Daten • Technical Data 233-234

Artikel Nr. Code No.	Typ Type	S	A	B	C	D	L	h	k	Max. Spannkraft [daN] Max. clamping force [daN]	kg
326624010900	6624-100	100	85	35	13	80	163,0	30	12	2.000	4,4
326624020000	6624-125	125	105	42	15	84	170,0	40	12	3.000	6,7
326624030200	6624-150	150	140	52	18	110	221,5	50	18	4.000	14,5
326624040400	6624-200	200	165	61	20	127	253,5	60	18	4.500	26,5

1
2
3
4
5
6
7

6622

6623

6624

6850

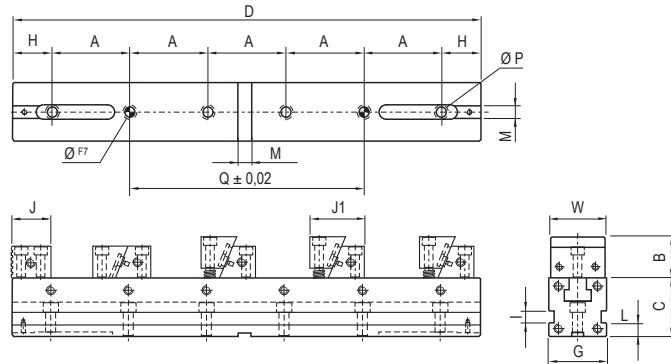
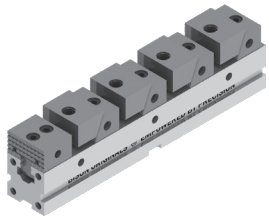

Artikel Nr. Code No.	Typ Type	A	B	C	D	G	J	J1	I	L	MH7	W	ØP	Q	ØF7	kg
326850530900	6850-50-300	100	32/25	50	300	50	38	55/58	12	15	16	49	9	100	10	7,20
326850540000	6850-50-400	100	32/25	50	400	50	38	55/58	12	15	16	49	9	100	10	8,70
326850550200	6850-50-500	100	32/25	50	500	50	38	55/58	12	15	16	49	9	300	10	10,10
326850560400	6850-50-600	100	32/25	50	600	50	38	55/58	12	15	16	49	9	300	10	11,60
326850570600	6850-50-700	100	32/25	50	700	50	38	55/58	12	15	16	49	9	400	10	13,00
326850740200	6850-75-400	100	40	75	400	75	50	70/75	16	20	16	74	13	300	16	22,45
326850750400	6850-75-500	100	40	75	500	75	50	70/75	16	20	16	74	13	200	16	25,95
326850760600	6850-75-600	100	40	75	600	75	50	70/75	16	20	16	74	13	300	16	29,45
326850770800	6850-75-700	100	40	75	700	75	50	70/75	16	20	16	74	13	400	16	32,95
326850780000	6850-75-800	100	40	75	800	75	50	70/75	16	20	16	74	13	500	16	36,40
326850170200	6850-100-700	100	60	100	700	100	70	94,5/98,5	12	20	16	99	17	400	16	65,10
326850180400	6850-100-800	100	60	100	800	100	70	94,5/98,5	12	20	16	99	17	500	16	70,60
326850190600	6850-100-900	100	60	100	900	100	70	94,5/98,5	12	20	16	99	17	400	16	77,60
326850100000	6850-100-1000	100	60	100	1000	100	70	94,5/98,5	12	20	16	100	17	500	16	83,30

6851

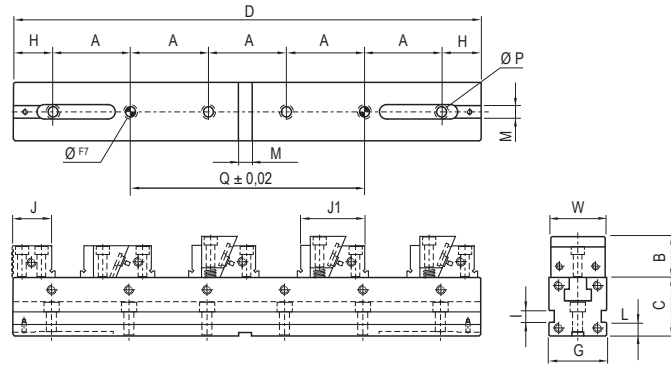
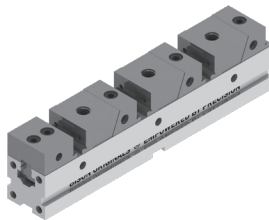

Artikel Nr. Code No.	Typ Type	A	B	C	D	G	J	J1	I	L	MH7	W	ØP	Q	ØF7	kg
326851530700	6851-50-300	100	32/25	50	300	50	38	65/68	12	15	16	49	9	100	10	7,25
326851540900	6851-50-400	100	32/25	50	400	50	38	65/68	12	15	16	49	9	100	10	8,80
326851550000	6851-50-500	100	32/25	50	500	50	38	65/68	12	15	16	49	9	300	10	10,20
326851560200	6851-50-600	100	32/25	50	600	50	38	65/68	12	15	16	49	9	300	10	11,70
326851570400	6851-50-700	100	32/25	50	700	50	38	65/68	12	15	16	49	9	400	10	13,85
326851740000	6851-75-400	100	40	75	400	75	50	83/88	16	20	16	74	13	300	16	21,90
326851750200	6851-75-500	100	40	75	500	75	50	83/88	16	20	16	74	13	200	16	25,40
326851760400	6851-75-600	100	40	75	600	75	50	83/88	16	20	16	74	13	300	16	28,90
326851770600	6851-75-700	100	40	75	700	75	50	83/88	16	20	16	74	13	400	16	32,40
326851780800	6851-75-800	100	40	75	800	75	50	83/88	16	20	16	74	13	500	16	38,10
326851170000	6851-100-700	100	60	100	700	100	70	109/113	12	20	16	99	17	400	16	68,30
326851180200	6851-100-800	100	60	100	800	100	70	109/113	12	20	16	99	17	500	16	73,80
326851190400	6851-100-900	100	60	100	900	100	70	109/113	12	20	16	99	17	400	16	81,00
326851100800	6851-100-1000	100	60	100	1000	100	70	109/113	12	20	16	100	17	500	16	86,50

6852

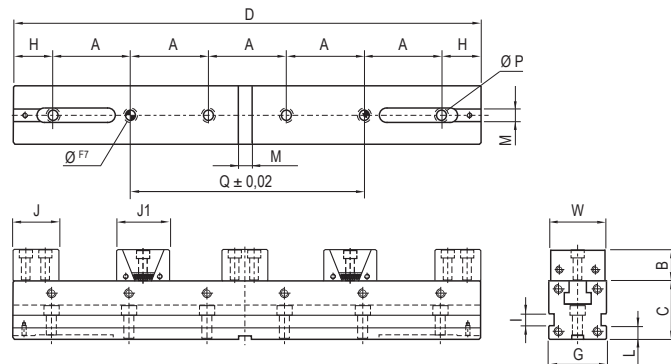
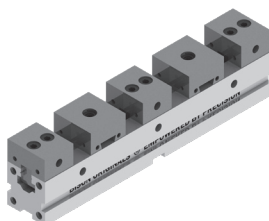

Artikel Nr. Code No.	Typ Type	A	B	C	D	G	J	J1	I	L	MH7	W	ØP	Q	ØF7	kg
326852530500	6852-50-300	100	25	50	300	50	38	44/50	12	15	16	49	9	100	10	6,60
326852540700	6852-50-400	100	25	50	400	50	38	44/50	12	15	16	49	9	100	10	8,10
326852550900	6852-50-500	100	25	50	500	50	38	44/50	12	15	16	49	9	300	10	9,50
326852560000	6852-50-600	100	25	50	600	50	38	44/50	12	15	16	49	9	300	10	11,00
326852570200	6852-50-700	100	25	50	700	50	38	44/50	12	15	16	49	9	400	10	12,50
326852740900	6852-75-400	100	40	75	400	75	50	52/58	16	20	16	74	13	300	16	20,79
326852750000	6852-75-500	100	40	75	500	75	50	52/58	16	20	16	74	13	200	16	24,29
326852760200	6852-75-600	100	40	75	600	75	50	52/58	16	20	16	74	13	300	16	27,79
326852770400	6852-75-700	100	40	75	700	75	50	52/58	16	20	16	74	13	400	16	31,29
326852780600	6852-75-800	100	40	75	800	75	50	52/58	16	20	16	74	13	500	16	34,80
326852170900	6852-100-700	100	60	100	700	100	70	84/90	12	20	16	99	17	400	16	63,00
326852180000	6852-100-800	100	60	100	800	100	70	84/90	12	20	16	99	17	500	16	68,50
326852190200	6852-100-900	100	60	100	900	100	70	84/90	12	20	16	99	17	400	16	74,00
326852100600	6852-100-1000	100	60	100	1000	100	70	84/90	12	20	16	100	17	500	16	79,50

6850

6851

6852

Eigenschaften:

- Erleichterte Handhabung durch das Pneumatik-System
- Die austauschbaren, gehärteten und geschliffenen Riffelbacken gewährleisten eine lange Lebensdauer
- Robuste Ausführung
- Großer Spannbereich
- Ausgestattet mit einem Sicherheitsventil

Eigenschaften:

- Für die Handhabung schwerer Werkstücke unter Einsatz hoher Spannkraft

Standardzubehör:

- Nutensteine

Features:

- Pneumatic system makes operation of the vice easy
- Removable grooved jaw inserts are hardened and ground
- Sturdy body
- Wide range of clamping
- Equipped with a safety valve

Application:

- These heavy duty machine vises are used in operations where a large clamping force is required

Standard accessories:

- Slot nuts

PNEUMATISCH BETÄTIGT
PNEUMATICALLY OPERATED

6710

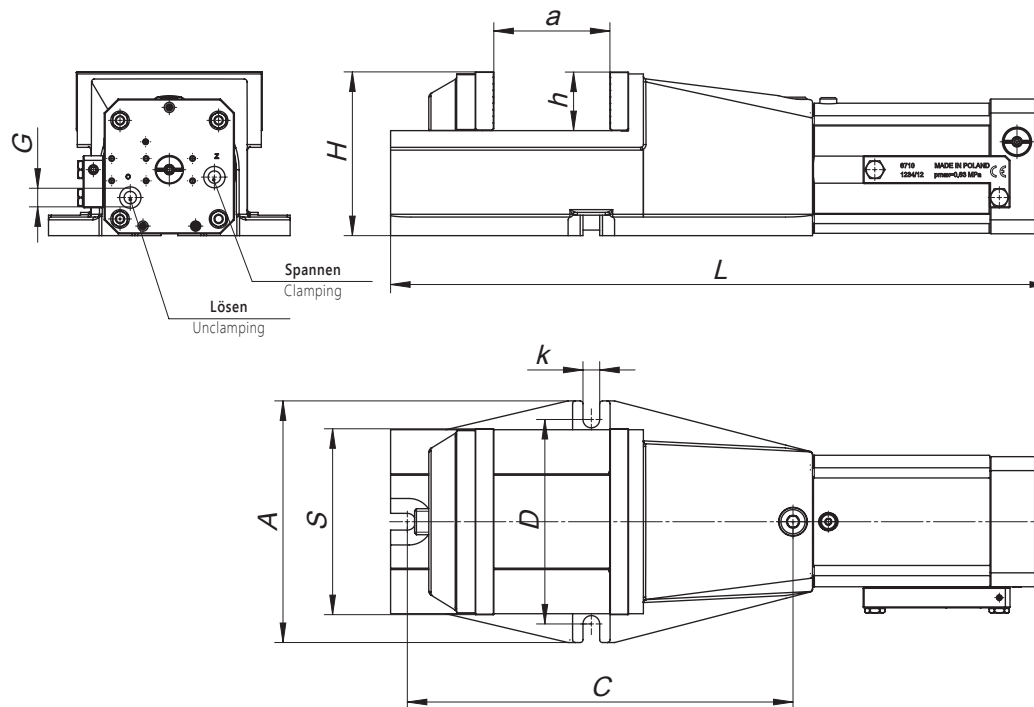

Artikel Nr. Code No.	Typ Type	A	H	L	a max	h	k	C	D	G	Backenhub Jaw stroke	Luftverbrauch [l] Air consumption [l]	Spannkraft für 0,63 MPa [daN] Clamping force for 0,63 MPa [daN]	kg
326710060400	6710-125	180	129	553	100	40	14	274	150	G3/8"	7	1,3	3.000	33,0
326710070600	6710-160	225	150	621	125	50	18	337	185	G3/8"	8	1,6	3.700	50,2
326710080800	6710-200	260	176	709	160	63	18	415	220	G3/8"	9	2,5	4.600	74,0

Zubehör • Accessories 220-232

- 1
- 2
- 3
- 4
- 5
- 6
- 7

6710

6512

MIT BEWEGLICHER BACKE
WITH MOVABLE REAR JAW

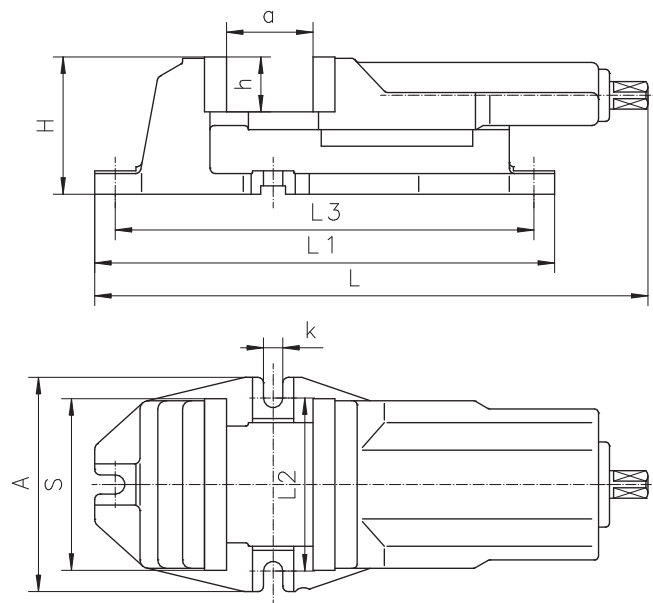

Artikel Nr. Code No.	Typ Type	S	A	H	L	L1	L2	L3	a	h	k	Max. Spannkraft [daN] Max. clamping force [daN]	kg
326512050600	6512-100	100	156	84	294	290	126	260	80	32	14	2.500	9,9
326512060800	6512-125	125	156	100	347	335	126	305	95	40	14	3.500	15,9
326512070000	6512-160	160	193	121	423	405	150	365	125	50	18	4.000	29,0
326512080100	6512-200	200	256	147	515	500	210	460	160	63	18	5.500	56,0
326512090300	6512-250	250	316	174	615	610	268	566	200	80	22	6.200	71,0

Eigenschaften:

- Die austauschbaren, gehärteten und geschliffenen Riffelbacken gewährleisten eine lange Lebensdauer
- Leitspindelabdeckung gegen Verschmutzung
- Körper und Backen aus hochwertigen Gussteilen gefertigt

Anwendung:

- Entwickelt für den Einsatz an Fräs- und Bohrmaschinen

Standardzubehör:

- Handkurbel
- Nutensteine

Features:

- Removable grooved jaw inserts are hardened and ground
- Lead screw protected against dirt and chips
- Body and movable jaw are high quality castings

Application:

- Designed for use with milling machines, drill presses, etc.

Standard accessories:

- Handcrank
- Slot nuts

Passende Drehplatte
Matching swivel base



Typ
Type

6582

Seite
Page

220

Zubehör • Accessories 220-232

1
2
3
4
5
6
7

6512

Eigenschaften:

- Einzigartige Hydraulikspindel erleichtert die Handhabung
- Die austauschbaren, gehärteten und geschliffenen Riffelbacken gewährleisten eine lange Lebensdauer
- Einfache Spannbereichverstellung mittels 2 Bolzen
- Körper und Backen aus hochwertigen Gussteilen gefertigt

Anwendung:

- Für die Handhabung schwerer Werkstücke unter Einsatz hoher Spannkraft

Standardzubehör:

- Handkurbel
- Nutensteine

Features:

- A unique, built-in hydraulic spindle makes operation of the vise easy
- Removable grooved jaw inserts are hardened and ground
- Easy adjusting of clamping range by means of 2 pins
- Sturdy, maintenance-free spindle
- Body and movable jaw are high quality castings

Application:

- These heavy duty machine vises are used in operations where a large clamping force is required

Standard accessories:

- Handcrank
- Slot nuts

MIT HYDRAULISCHER SPINDEL
WITH HYDRAULIC SPINDLE

6516

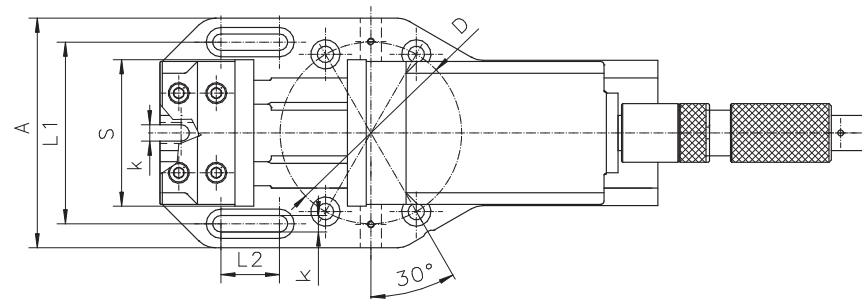
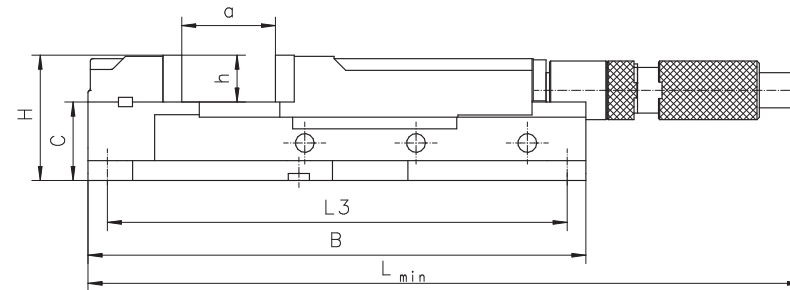
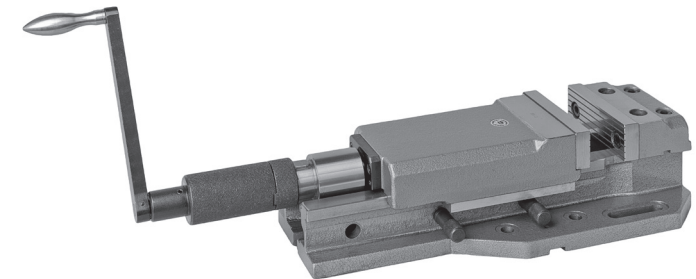

Passende Drehplatte
Matching swivel base



Typ 6585 Seite 221
Type Page

Zubehör • Accessories 220-232

Artikel Nr. Code No.	Typ Type	S	A	B	C	H	L	L1	L2	L3	D	a	h	k	Max. Spannkraft [daN] Max. clamping force [daN]	kg
326516120400	6516-M125	125	196	425	67	109	530	155	50	389	155	205	42	14	3.500	19,9
326516130600	6516-M160	160	246	565	80	130	615	200	65	525	200	280	50	18	5.500	52,4
326516140800	6516-M200	200	304	675	99	162	795	250	90	635	250	375	63	18	7.500	93,0

- 1
- 2
- 3
- 4
- 5
- 6
- 7

6516

6517

MIT ABSCHNITTSEWEISER SCHNELLVERSTELLUNG
CAMLOCK MACHINE VISE

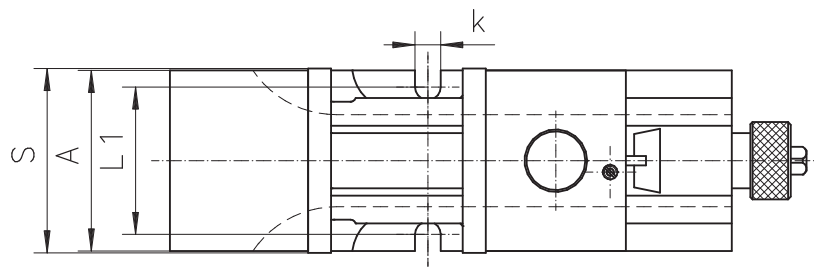
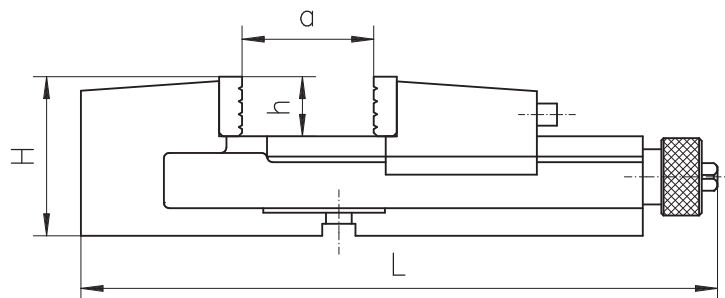
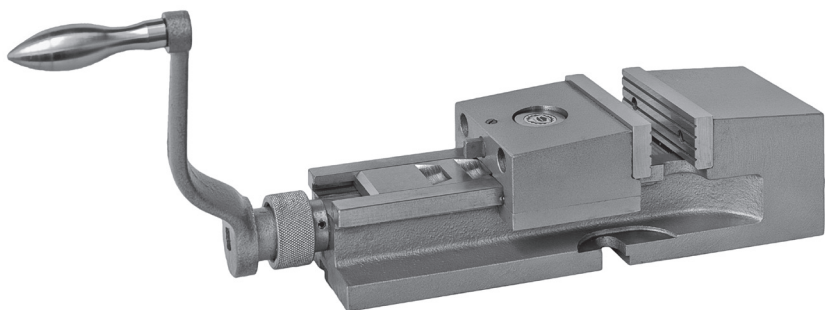

Eigenschaften:

- Die bewegliche Backe ist zur Spannbereichsverstellung mittels einzigartigem Camlock-System einfach versetzbar
- Die austauschbaren, gehärteten und geschliffenen Riffelbacken gewährleisten eine lange Lebensdauer
- Leitspindelabdeckung gegen Verschmutzung
- Komplet geschliffene Backenführung
- Körper und feste Backe aus hochwertigen Gussteilen

Anwendung:

- Entwickelt für Fräs- und Bohrmaschinen, etc.

Standardzubehör:

- Handkurbel
- Nutensteine

Features:

- The movable rear jaw can be placed in different positions through a unique cam locking system, making the rear jaw positioning fast and easy
- Removable grooved jaw inserts, one side smooth, the other side grooved, are hardened and ground
- Fully covered lead screw protected against dirt and chips
- Fully ground steel position beam
- Body and rear jaw are high quality castings

Application:

- Designed for use with milling machines, drill presses, etc.

Standard accessories:

- Handcrank
- Slot nuts

Artikel Nr. Code No.	Typ Type	S	A	H	L	L1	a	h	k	Max. Spannkraft [daN] Max. clamping force [daN]	kg
326517150800	6517-M100	100	98	85	346	80	125	32	14	1.800	10,6
326517160000	6517-M125	125	122	105	418	101	160	40	14	2.500	20,4
326517170100	6517-M160	160	156	125	524	126	180	50	18	4.200	38,0
326517180300	6517-M200	200	194	150	695	160	280	63	18	6.200	78,0

Passende Drehplatte
Matching swivel base



Typ
Type

6587

Seite
Page

222

Zubehör • Accessories 220-232

1
2
3
4
5
6
7

6517

Eigenschaften:

- Erhöhte Nutzung des gesamten Maschinenbettes
- Die austauschbaren, geriffelten Backeneinsätze, gehärtet und geschliffen, gewährleisten eine lange Lebensdauer
- Beide Backenkörper aus hochwertigen Gussteilen

Anwendung:

- Ideal für große Spannbereiche

Standardzubehör:

- Handkurbel
- Nutensteine

Features:

- Facilitates utilization of the full length of the machine bed
- Removable, grooved jaw inserts are hardened and ground
- Clamp base body and rigid base are high quality castings

Application:

- Designed for use where a large clamping force is required

Standard accessories:

- Handcrank
- Slot nuts

GETEILTER SCHRAUBSTOCK
TWO-PIECE MACHINE VISE

6522

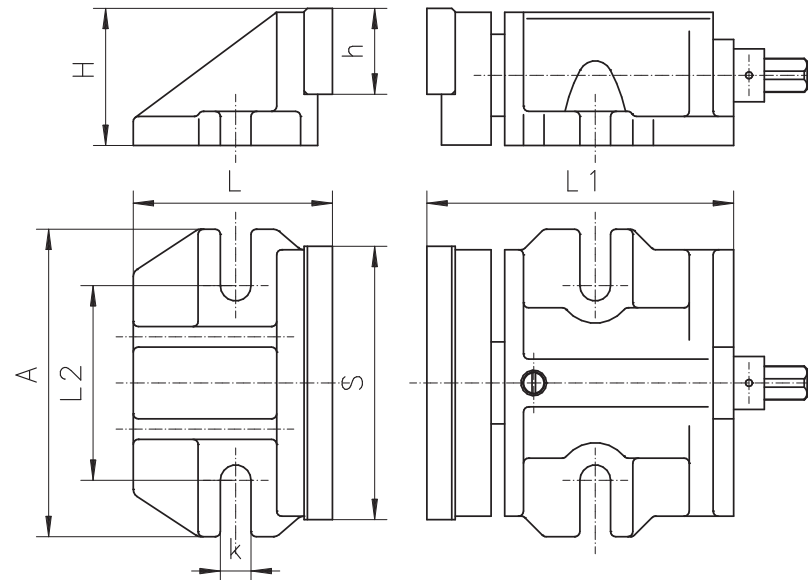
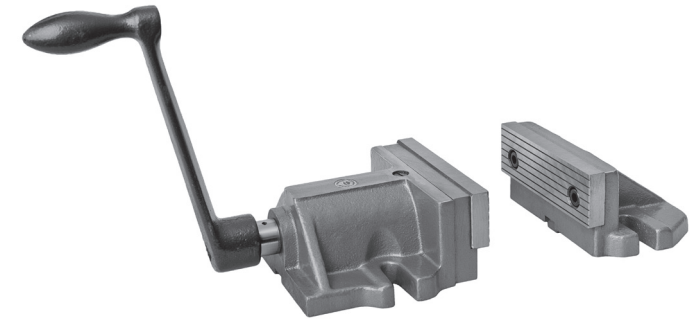

Artikel Nr. Code No.	Typ Type	S	A	H	L	L1	L2	h	k	Max. Spannkraft [daN] Max. clamping force [daN]	kg
326522040100	6522-160	160	180	80	160	194	114	50	17	4000	14,5
326522050300	6522-200	200	196	100	172	258	130	63	17	5000	26,2

Zubehör • Accessories 220-232

- 1
- 2
- 3
- 4
- 5
- 6
- 7

6522

6523

MIT HOHER HALTEKRAFT
HOLD-TIGHT MACHINE VISE

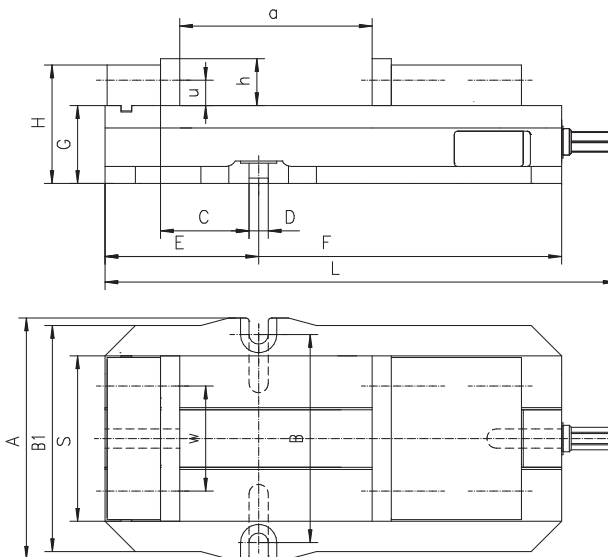
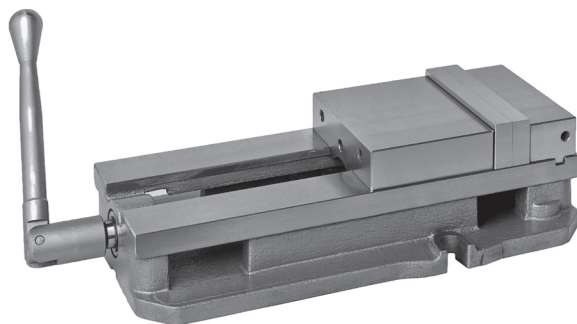

Eigenschaften:

- Möglichkeit 4 verschiedene Backeneinsätze zu nutzen, abhängig vom erforderlichen Spannbereich der Werkstücke
- Körper und bewegliche Backe sind aus hochwertigen Gussteilen, die fixe Backe aus hochqualitativem Konstruktionsstahl gefertigt

Anwendung:

- Für Arbeiten mit Fräs-, Bohr-, und Schleifmaschinen mit Anspruch nach hoher Genauigkeit und sicherem Werkstückhalt

Standardzubehör:

- Handkurbel
- Nutensteine

Features:

- Possible to secure the jaws in 4 different positions, increasing the clamping range of workpieces
- Steel jaw inserts, formed according to client's requirements, are hardened and ground, ensuring longer life with maintained accuracy and repeatability
- Body and movable jaw are made of high-quality cast iron

Application:

- Designed for use with milling machines, drill presses, grinders, etc. and other work that requires high accuracy and safe clamping

Standard accessories:

- Handcrank
- Slot nuts

Die max. Länge des Werkstückes (in mm) hängt von der Befestigung der Backeneinsätze ab
Maximum length of workpiece (mm) depends on how the jaw inserts are secured

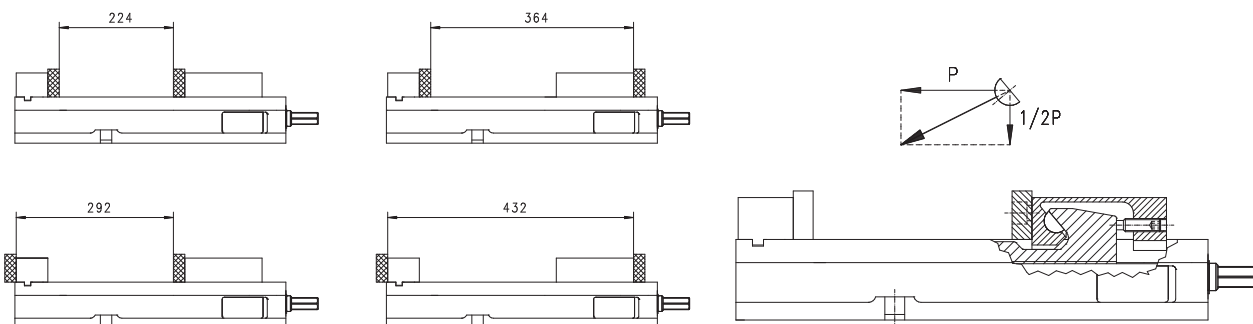

Artikel Nr. Code No.	Typ Type	S	A	B	B1	C	D H7	E	F	G ±0,013	H -0,08	L	a	h	u	w	Max. Spannkraft [daN] Max. clamping force [daN]	kg
326523160400	6523-155L	155L	226	195	212	83	18	144	428	73,025	111	479	224	44	23,8	98,4	4.500	34,2

Passende Drehplatte
Matching swivel base



Typ
Type 6588 Seite
Page 222

Zubehör • Accessories 220-232

1
2
3
4
5
6
7

6523

Eigenschaften:

- Neigungswinkel der Horizontalen bis zu 90° verstellbar
- Drehplatte mit 360° Gradeinteilung und geschliffener Auflage
- Die austauschbaren, gehärteten und geschliffenen Riffelbacken gewährleisten eine lange Lebensdauer
- Robuste Bauweise mit Komplettabdeckung der Leitspindel, schützt diese vor Schmutz

Anwendung:

- Geeignet zum Fräsen, Hobeln und Bohren, speziell wenn Winkeleinstellungen erforderlich sind

Standardzubehör:

- Handkurbel
- Nutensteine

Features:

- Up to 90° angle of incline from the horizontal position
- 360° swivel base with ground contact edge and graduation
- Removable grooved jaw inserts are hardened and ground,
- Sturdy design of fully covered cast iron lead screw

Application:

- Designed for milling, planing and drilling when two angle settings occur

Standard accessories:

- Handcrank
- Slot nuts

NEIG- UND DREHBAR
TWO ANGLE SWIVEL MACHINE VISE

6530

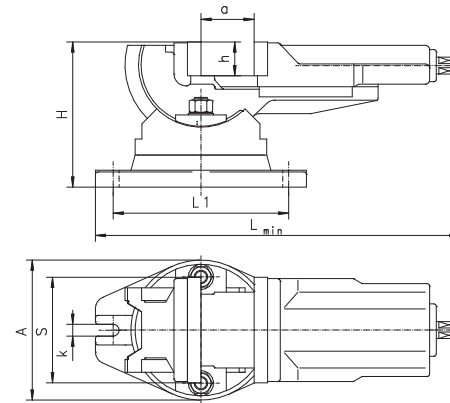

Artikel Nr. Code No.	Typ Type	S	A	H	L L _{min}	L1	a	h	k	Max. Spannkraft [daN] Max. clamping force [daN]	kg
326530050400	6530-100	100	144	145	372	181	80	32	14	2.500	12,5
326530060600	6530-125	125	168	169	437	208	100	40	14	3.500	20,0
326530070800	6530-160	160	212	200	450	208	125	50	18	4.500	34,2

Zubehör • Accessories 220-232

Eigenschaften:

- Drehplatte mit 360° Gradeinteilung und geschliffener Auflage
- Die austauschbaren, gehärtete und geschliffenen Riffelbacken gewährleisten eine lange Lebensdauer
- Robuste Gusseisen-Ausführung

Anwendung:

- Ideal für verschiedene Arten von Fräs- und Hobelarbeiten

Standardzubehör:

- Handkurbel
- Nutensteine

Features:

- 360° swivel base with ground contact edge and graduation
- Removable grooved jaw inserts are hardened and ground
- Sturdy design of cast iron

Application:

- Designed for various types of milling and planing of forms, slots and grooves

Standard accessories:

- Handcrank
- Slot nuts

SELBSTZENTRIEREND UND DREHBAR
SELF-CENTERING MACHINE VISE

6531

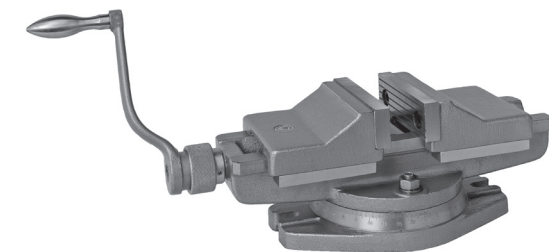
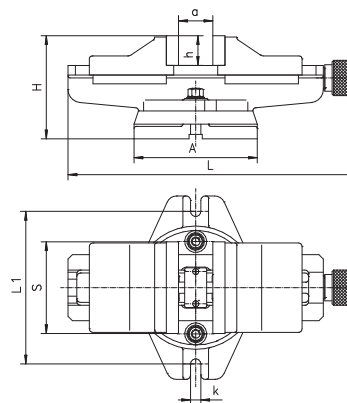

Artikel Nr. Code No.	Typ Type	S	A	H	L	L1	a	h	k	Max. Spannkraft [daN] Max. clamping force [daN]	kg
326531060400	6531-125	125	168	136	458	208	100	40	14	2.500	19,2
326531070600	6531-160	160	212	169	534	248	125	50	18	4.000	33,5
326531080800	6531-200	200	286	185	591	333	160	63	18	5.500	59,0

Zubehör • Accessories 220-232

- 1
- 2
- 3
- 4
- 5
- 6
- 7

6530

6531

6534

DREH-, NEIG- UND SCHWENKBAR
THREE ANGLE MULTI-PURPOSE MACHINE VISE

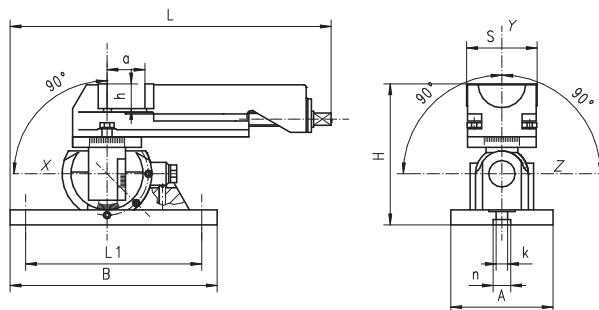
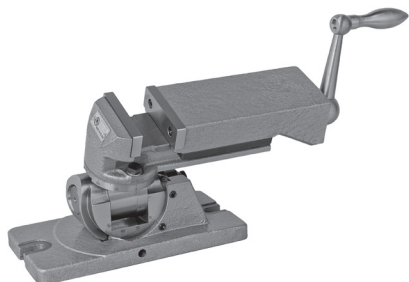

Eigenschaften:

- Hergestellt aus hochwertigem Grauguss
- Die Beweglichkeit um die „y“-Achse beträgt 360°
- Schwenkbar innerhalb 90° in zwei Richtungen um die „x“- und von vertikaler in horizontaler Position um die „z“-Achse
- Die Genauigkeit ist in jedem Winkel der 3 Achsen gleich 30'

Anwendung:

- Zum Schleifen von Oberflächen, geeignet in verschiedenen Ebenen zur Grundfläche, zum Herstellen von Bohrungen auf schrägen Flächen sowie zum präzisen Fräsen mit niedrigen Zerspanungskräften

Standardzubehör:

- Handkurbel
- Haltebolzen

Features:

- Made of high quality iron castings
- Rotation in „y“ axis within 360°
- Can tilt in two directions within 90° around „x“ axis and tilt within 90° from vertical to horizontal position around „z“ axis
- Accuracy in every angular position in 3 axes equal to 30'

Application:

- For the grinding of surfaces rotated in one or several planes from the base, spotting and drilling holes in such surfaces and for precise milling at low cutting forces

Standard accessories:

- Handcrank
- Clamping bolts

Artikel Nr. Code No.	Typ Type	S	A	B	H	L	L1	a	h	k	n	Max. Spannkraft [daN] Max. clamping force [daN]	kg
326534020100	6534-80M	80	116	235	160	321,5	199	63	25	13	20	1000	12,2

Zubehör • Accessories 220-232

6540

MIT SCHNELLVERSTELLUNG, KONTINUIERLICH
QUICK-ACTING MACHINE VISE

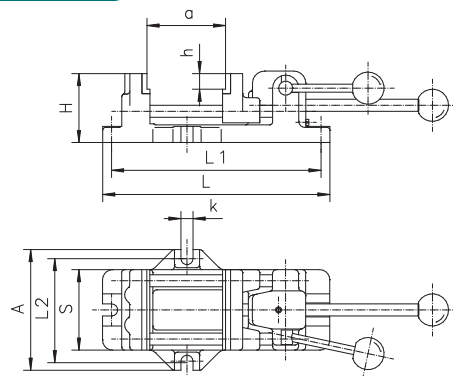
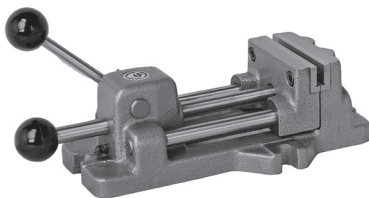

Eigenschaften:

- Der Schnellverstell-Klemmmechanismus erlaubt rasche Werkstückwechsel und minimierte Einstellzeit
- Gestufte Backeneinsätze erlauben eine plane Werkstückaufnahme
- Führungsgestänge und Klemmmechanismus sind zur Gewährleistung einer langen Lebensdauer gehärtet und geschliffen
- Austauschbare Backeneinsätze
- Gehärtet und schwarzgebrannt
- Körper und Backen aus hochwertigen Gussteilen gefertigt

Anwendung:

- Für Bohr- und Fräsarbeiten mit raschem Werkstückwechsel

Features:

- The initial clamping is done by the movable jaw, placed closely to the workpiece
- Final clamping of the workpiece is performed by the lever movement of the quick-acting cam-mechanism, which minimizes the required setting time
- Recessed jaw inserts for convenient leveling of workpiece
- Guiding rods and cam mechanism are hardened and ground
- Removable jaw inserts are hardened and blackened
- Body and movable jaw are high quality castings

Application:

- Designed for milling and drilling operations and instant setting of the workpiece

Artikel Nr. Code No.	Typ Type	S	A	H	L	L1	L2	a	h	k	Max. Spannkraft [daN] Max. clamping force [daN]	kg
326540040000	6540-80	80	120	68	226	208	102	80	16,5	12	350	4,0
326540050100	6540-100	100	160	85	293	257	124	125	16,5	14	400	7,0
326540060300	6540-125	125	185	90	330	292	147	150	16,5	14	500	10,0
326540070500	6540-160	160	224	95	380	340	184	160	16,5	18	600	15,5

Zubehör • Accessories 220-232

Eigenschaften:

- Das Spannen des Werkstückes wird durch eine einzelne Drehbewegung des Hebels durchgeführt
- Die feststehende prismatische Backe erlaubt ein kraftvolles Spannen von flachen sowie runden Werkstücken
- Der Klemmmechanismus ist zur Gewährleistung einer langen Lebensdauer gehärtet und geschliffen
- Austauschbare Backeneinsätze, gehärtet und schwarzgebrannt

- Körper und Backen aus hochwertigen Gussteilen gefertigt

Anwendung:

- Speziell für Fräs- und Bohrarbeiten in der Serienproduktion entwickelt

Features:

- The clamping of the workpiece is performed by a single rotary movement of the lever

- The V-block is fastened to the fixed jaw, which enables the clamping of bars

- V-block enables horizontal or vertical clamping of flat or round workpieces

- Cam mechanism is hardened and ground removable jaw inserts are hardened and blackened

- Body and movable jaw are high quality castings

Application:

- Designed for milling and drilling operations, especially for series machining and instant setting of the workpiece

MIT SCHNELLVERSTELLUNG, KONTINUIERLICH
QUICK-ACTING MACHINE VISE

6542

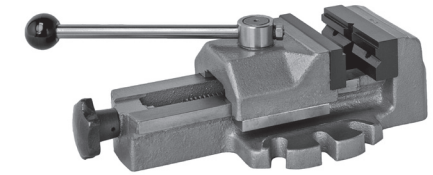
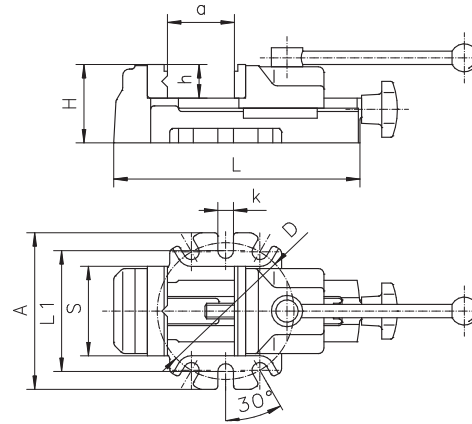

Artikel Nr. Code No.	Typ Type	S	A	H	L	L1	D	a	h	k	Schnell-Spannbereich		kg
											Max. quick grip jaw stroke	Max. clamping force [daN]	
326542040600	6542-80	80	140	70	220	108	122	80	30	14	4	800	5,2
326542050800	6542-100	100	165	80	270	133	140	100	35	14	4	1.200	8,9

Zubehör • Accessories 220-232

Eigenschaften:

- Vertikale und horizontale V-Nuten in der fixen Backe sowie eine Abstufung beider Backen erlauben das Spannen unterschiedlichster runder und flacher Werkstücke

- Der Körper ist aus hochqualitativem Gusseisen gefertigt

Anwendung:

- Ideal für die meisten Bohr- und leichte Fräsarbeiten

Features:

- Vertical and horizontal V-grooves on the fixed jaw insert and recesses of both jaws enable a wide variety of workpieces to be clamped

- Body is made of high quality castings

Application:

- Ideal for most drilling and light milling operations

BOHRMASCHINEN-SCHRAUBSTOCK
DRILLING MACHINE VISE

6543

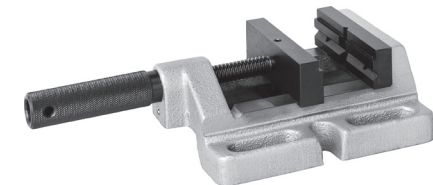
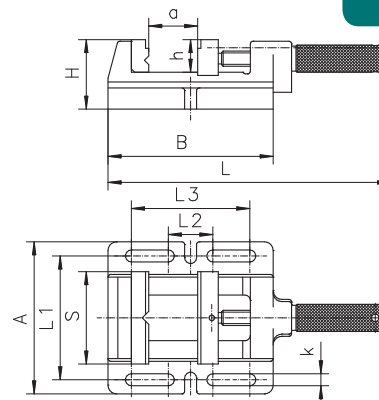

Artikel Nr. Code No.	Typ Type	S	A	B	H	L	L1	L2	L3	a	h	k	Max. Spannkraft [daN]		kg
													Max. clamping force [daN]		
326543540900	6543-85M	85	140	152	64	265	114	41	109	70	30	11	400		3,4
326543550000	6543-100M	100	152	170	64	285	124	57	127	85	30	13	500		4,0
326543560200	6543-120M	120	176	212	64	360	148	71	169	120	30	13	650		5,0
326543570400	6543-150M	150	208	262	66	442	178	75	209	150	38	13	800		8,4

Zubehör • Accessories 220-232

1
2
3
4
5
6
7

6542

6543

6546

WELLEN-SCHRAUBSTOCK
SHAFT HOLDING MACHINE VISE

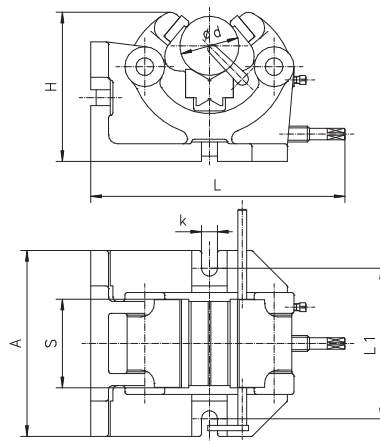
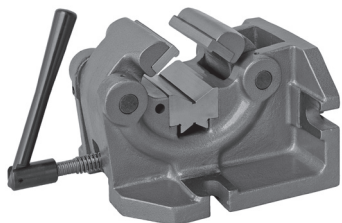

Eigenschaften:

- In horizontaler und vertikaler Positionen einsetzbar
- V-Block und Backeneinsätze gehärtet und geschliffen
- Robuste Gusseisen-Ausführung

Anwendung:

- Ideal für Bohr- und einfache Fräsarbeiten

Standardzubehör:

- Handkurbel
- Nutensteine

Features:

- Able to be set up in both horizontal and vertical positions
- Hardened and ground jaw inserts and V-block
- Sturdy, cast iron design

Application:

- Ideal for most drilling and light milling operations

Standard accessories:

- Handcrank
- Slot nuts

Artikel Nr. Code No.	Typ Type	S	A	H	L	L1	d	k	Max. Spannkraft [daN] Max. clamping force [daN]		kg
									326545130000	6546-100	
326545140100	6546-125	125	200	235	405	160	15-100	18	1.500	38,0	
326545150300	6546-160	160	300	295	460	256	50-160	18	2.000	75,0	

Zubehör • Accessories 220-232

6910

MIT PRISMATISCHER BACKENFÜHRUNG
MACHINE VISE WITH PRISMATIC GUIDANCE OF MOVABLE JAW

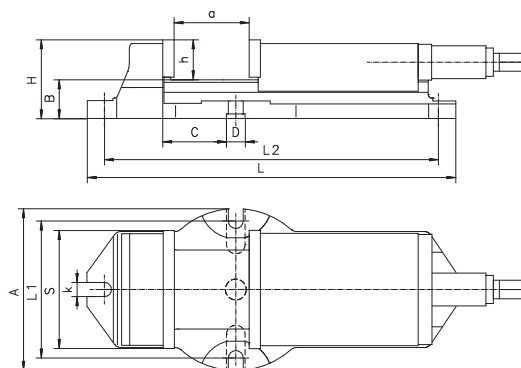
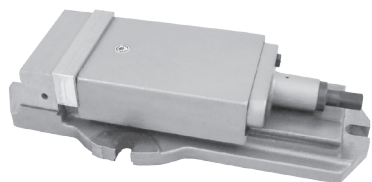

Eigenschaften:

- Glatte Backen, gehärtet und geschliffen, gewährleisten eine lange Lebensdauer
- Durchgängige Abdeckung der Leitspindel und Führung in Bronzebuchsen schützt vor Verschmutzung und gewährleistet leichtgängige Handhabung
- Körper und Backen aus hochwertigen Gussteilen gefertigt

Anwendung:

- Für Arbeiten mit Fräs-, Bohrmaschinen, etc.

Standardzubehör:

- Einstellbarer Endanschlag
- Handkurbel
- Nutensteine

Features:

- Smooth jaw inserts are hardened and ground, ensuring longer life with maintained accuracy and repeatability
- Fully covered lead screw in a bronze nut protects against dirt and chips
- Body and movable jaw are high quality castings

Application:

- Designed for use with milling machines, drill presses, etc

Standard accessories:

- Adjustable end-stop
- Handcrank
- Slot nuts

Artikel Nr. Code No.	Typ Type	S	A	B	C	D	H	L	L1	L2	a	h	k	Max. Spannkraft [daN] Max. clamping force [daN]		kg
														326910000600	6910-105	
326910020000	6910-155	155	215	52	85,5	25	105	495	183	449	165	53	20	3.800	36,4	
326910030100	6910-210	210	268	67	103,5	25	126	593	236	549	205	59	20	5.300	68,2	

Passende Drehplatte
Matching swivel base



Typ
Type 6583 Seite
Page 220

Zubehör • Accessories 220-232

- Für Präzisions-, Schleif-, Fräs- und Messarbeiten,
- Hergestellt aus legiertem Werkzeugstahl, gehärtet und präzisionsgeschliffen

- Used for precision grinding, milling and measuring work
- Made of alloy tool steel, hardened and precision ground

WM-SCHRAUBSTOCK MIT GLATTEN BACKEN
PLAIN JAW

6552

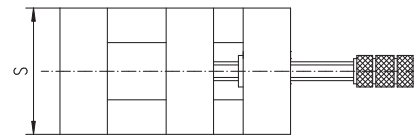
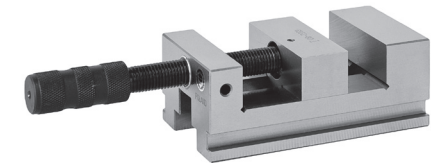
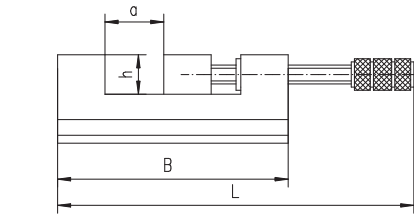

Artikel Nr. Code No.	Typ Type	S	B	H	L	a max.	h	kg
326552030100	6552-63	63	120	47	182	50	20	1,8
326552040300	6552-80	80	146	56	215	63	25	4,2
326552050500	6552-100	100	174	71	243	80	32	8,5

Zubehör • Accessories 220-232

- Auf die gleiche Weise konstruiert wie Typ 6552 mit Ausnahme der beweglichen prismatischen Backe

- Constructed in the same manner as above, except in movable jaw a ground vertical prism is provided

WM-SCHRAUBSTOCK MIT PRISMATISCHER BACKE
WITH VERTICAL PRISM

6553

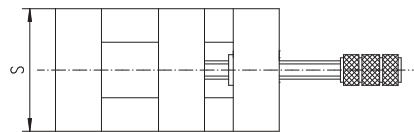
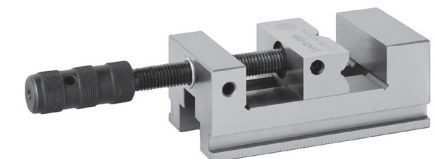
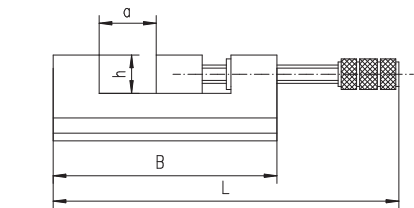

Artikel Nr. Code No.	Typ Type	S	B	H	L	a max.	h	kg
326553030000	6553-63	63	120	47	182	50	20	1,8
326553040100	6553-80	80	146	56	215	63	25	4,2
326553050300	6553-100	100	174	71	243	80	32	8,5

Zubehör • Accessories 220-232

- 1
- 2
- 3
- 4
- 5
- 6
- 7

- 6552
6553

6554

MIT BEWEGLICHER QUERACHSE
WITH FRONT SWIVELLING AXIS

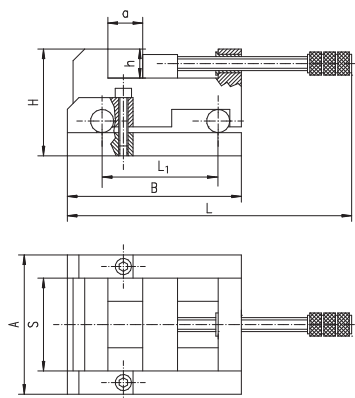

Eigenschaften:

- Der Schraubstock kann in jedem Winkel seiner Bewegung fixiert werden
 - Genaue Einstellung erfolgt mittels Endmaßen
 - Gelenke gehärtet, mit Genauigkeit von 0.001 mm geschliffen
 - Gefertigt aus legiertem Stahl, gehärtet und geschliffen
- Anwendung:**
- Für Präzisions-, Schleif-, Fräs- und Messarbeiten

Features:

- Vise can be positively locked in any desired angular position
 - Accurate angle setting by means of gauge blocks
 - Pivots hardened and ground with an accuracy of 0,001 mm
 - Made of alloy tool steel, hardened and precision ground
- Application:**
- Designed for precision grinding, milling and measuring work

Artikel Nr. Code No.	Typ Type	S	A	B	H	L	L1	a max.	h	kg
326554030800	6554-63	63	103	140	83	215	100	50	20	2,5
326554040000	6554-80	80	120	150	92	216	100	63	25	7,0
326554050100	6554-100	100	144	164	108	243	100	80	32	10,2

Zubehör • Accessories 220-232

6555

MIT BEWEGLICHER LÄNGSACHSE
WITH LONGITUDAL SWIVELLING AXIS

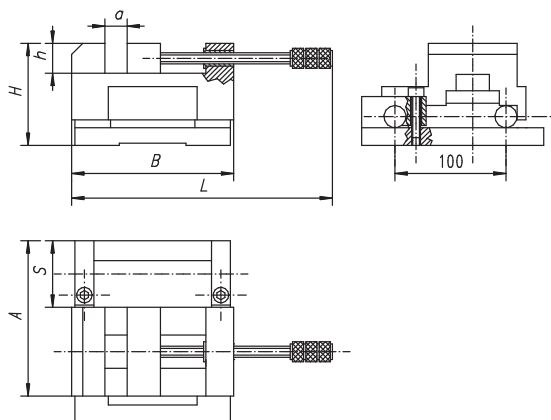
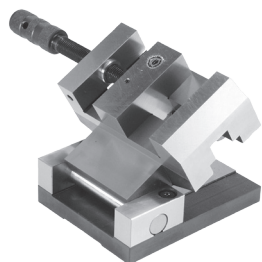

Eigenschaften:

- Der Schraubstock kann in jedem Winkel seiner Bewegung fixiert werden
 - Genaue Einstellung erfolgt mittels Endmaßen
 - Gelenke gehärtet, mit Genauigkeit von 0.001 mm geschliffen
 - Gefertigt aus legiertem Stahl, gehärtet und geschliffen
- Anwendung:**
- Für Präzisions-, Schleif-, Fräs- und Messarbeiten

Features:

- Vise can be positively locked in any desired angular position
 - Accurate angle setting by means of gauge blocks
 - Pivots hardened and ground with an accuracy of 0,001 mm
 - Made of alloy tool steel, hardened and ground
- Application:**
- Designed for precision grinding, milling and measuring work

Artikel Nr. Code No.	Typ Type	S	A	B	H	L	a max.	h	kg
326555040800	6555-80	80	153	146	92	215	63	27	8,55

Zubehör • Accessories 220-232

Eigenschaften:

- Induktionsgehärtete und geschliffene Stahlbacken-Einsätze, mit vertikalen und horizontalen Aussparungen zur Aufnahme runder Werkstücke
- Leitspindelabdeckung gegen Verschmutzung
- Fester Körper und bewegliche hintere Backe

Anwendung:

- Dieser hochqualitative, robuste Schraubstock ist besonders geeignet für hohe Beanspruchung

Features:

- Steel jaw inserts induction hardened and ground. Jaw inserts with vertical and horizontal recesses for clamping round workpieces
- Lead-screw completely covered to keep dirt out
- Fixed base and movable back jaw

Application:

- This high quality, rugged vise with dovetail guides is well-suited to extra heavy work

SCHWERLAST-SCHRAUBSTOCK
HEAVY DUTY TABLE VISE

1240

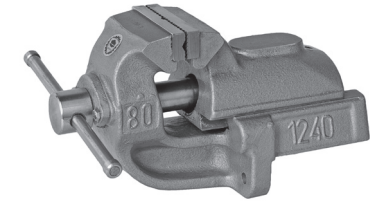
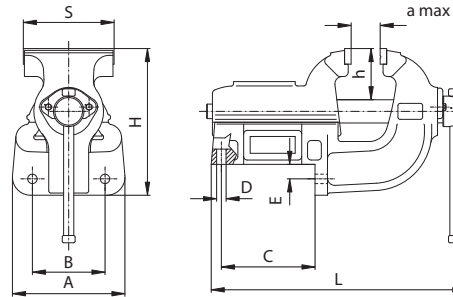

Artikel Nr. Code No.	Typ Type	S	A	B	C	D	E	H	L	a	h	Max. Spannkraft [daN]	kg
												Max. clamping force [daN]	
321240140400	1240-80L	80	115	85	87	9	16	140	250	100	51	2.000	6,8
321240150600	1240-100L	100	115	85	87	9	16	140	250	100	51	2.400	7,4
321240160800	1240-125L	125	155	100	129	13	20	200	354	140	71	2.800	18,0
321240170000	1240-150L	150	180	125	187	13	20	222	437	175	79	3.600	31,0
321240180100	1240-175L	175	180	125	187	13	20	222	437	175	79	4.000	32,0
321240190300	1240-200L	200	214	150	232	15	26	268	585	250	90	4.300	59,0
321240200800	1240-250L	250	214	150	232	15	26	268	585	250	90	4.500	61,5

Zubehör • Accessories 220-232

Eigenschaften:

- Robuste Ausführung, Korpus aus hochqualitativem Gusseisen; Backen, Basis und die restlichen Teile aus legiertem Stahl
- Induktionsgehärtete und geschliffene Stahlbacken-Einsätze
- Vertikale und horizontale Aussparungen zur Aufnahme runder Werkstücke
- Leitspindelabdeckung gegen Verschmutzung

Anwendung:

- Für Arbeiten mit Fräs-, Bohrmaschinen, etc.

Features:

- Ruggedly constructed with body and jaws made of high quality cast iron and other parts of alloy steel
- Steel jaw inserts induction hardened and ground, file cut for good grip
- Jaw inserts with vertical and horizontal recesses for clamping round workpieces
- Lead-screw completely covered to keep dirt out

Application:

- Designed for use with milling machines, drill presses, etc.

SCHWERLAST-SCHRAUBSTOCK
HEAVY DUTY BENCH VISE

1250

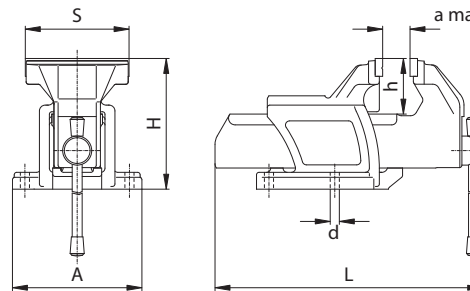

Artikel Nr. Code No.	Typ Type	S	A	H	L	a	d	h	Max. Spannkraft [daN]	kg
									Max. clamping force [daN]	
321250030900	1250-63L	63	120	112	229	63	9	45	1.200	4,0
321250040000	1250-80L	80	137	137	280	80	11	58	1.800	6,6
321250150300	1250-100L	100	137	137	282	80	11	58	2.200	7,5
321250160500	1250-125L	125	156	156	323	100	11	65	2.600	10,5
321250170700	1250-150L	150	170	182	380	125	13	75	3.400	16,2
321250180900	1250-175L	175	190	202	434	150	13	90	3.800	23,0

Passende Drehplatte
Matching swivel base

	Typ Type	1282	Seite Page	223
--	-------------	------	---------------	-----

Zubehör • Accessories 220-232

- 1
- 2
- 3
- 4
- 5
- 6
- 7

- 1240
- 1250

1253

SCHMIEDE-SCHRAUBSTOCK
BLACKSMITH'S VISE

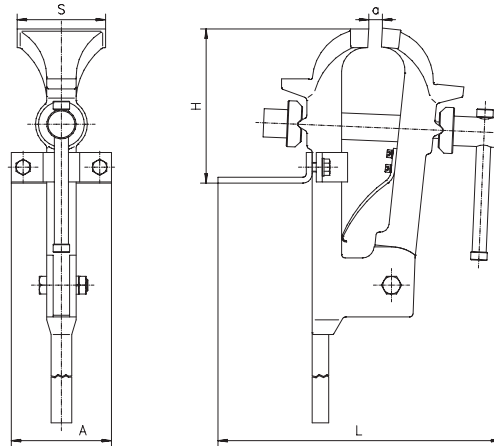
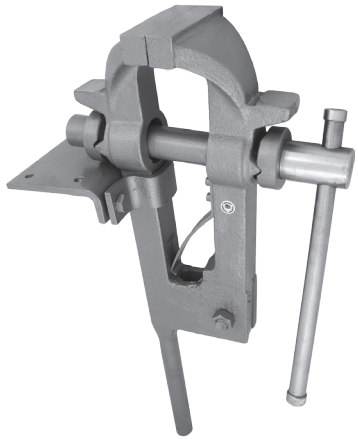

Eigenschaften:

- Feste und bewegliche Backe sind aus hochwertigen Stahlgussteilen gefertigt der Rest ist aus Konstruktionsstahl
- Die Rändelung der Backenflächen gewährleistet einen festen und sicheren Halt des Werkstückes

Anwendung:

- Hergestellt für die hohe Beanspruchung beim Einsatz in Schlosserei- und Schmiedebetrieben

Features:

- Fixed and movable jaws are made of high-grade steel castings
- Knurl cut in jaw clamping surfaces ensures firm and safe clamping

Application:

- Designed to be used for extra heavy locksmith's and blacksmith's work

Artikel Nr. Code No.	Typ Type	S	A	B	H	L	a max.	Max. Spannkraft [daN] Max. clamping force [daN]	kg
321253170100	1253-150M	150	170	820	255	465	135	3.700	36,6

1256

MOBILER SCHRAUBSTOCK, DREHBAR
PORTABLE VISE WITH SWIVEL BASE

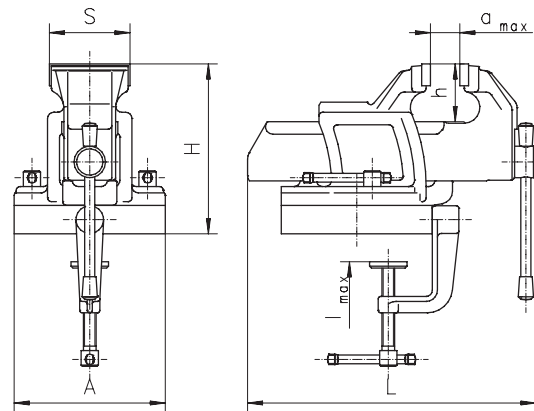

Eigenschaften:

- Ähnlich wie der Schraubstock Typ 1255
- Drehplatte in jeder beliebigen Position fixierbar
- Anbringung auf einer Werkbank mit einer Plattenstärke von max. 52mm möglich

Features:

- Design is similar to Type 1255
- Swivel base enables the vise to be positioned at any angle
- Must not be fixed to a bench thicker than 52mm

Artikel Nr. Code No.	Typ Type	S	A	H	L	a max.	h	l	Max. Spannkraft [daN] Max. clamping force [daN]	kg
321256030800	1256-63	63	120	131	228	63	45	52	1.200	5

Eigenschaften:

- Korpus aus hochqualitativem Gusseisen, die anderen Teile inklusive der beweglichen Backen sind aus gehärtetem Stahl

Anwendung:

- Dieser Schraubstock eignet sich für die Bearbeitung von beliebig langen Rohren

Features:

- Body is made of high quality cast iron while other parts, including movable jaw are made of steel and hardened

Application:

- This vise is designed for the clamping and working of pipes and tubes of any length

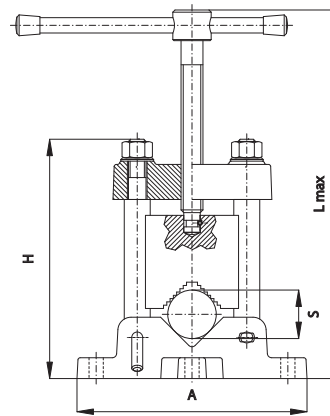

ROHR-SCHRAUBSTOCK
BENCH VISE FOR PIPES

1710

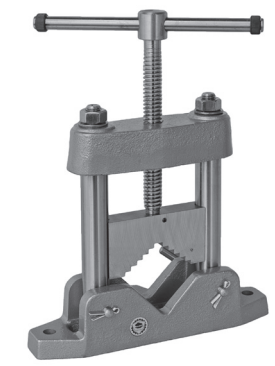

Artikel Nr. Code No.	Typ Type	S	A	B	H	L max.	Max. Spannkraft [daN]		
							Max. clamping force [daN]		kg
321710020000	1710-50	15-50	210	98	218	360	2.800		6
321710040300	1710-80	22-80	270	108	250	400	2.800		9

Eigenschaften:

- Aus geschweißten Stahlprofilen gefertigt
- Teleskopfuß ermöglicht einfachen Aufbau und Transport

Anwendung:

- Leichtgewichtige Basis für Rohr-Schraubstock Typ 1710

Features:

- Welded together from steel profiles
- Telescopic foot makes quick assembly and portability possible

Application:

- Lightweight portable base for 1710 vise

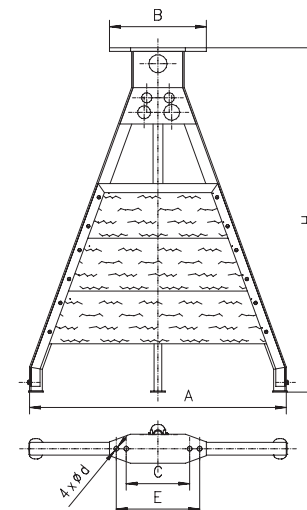

DREIBEINSTATIV FÜR ROHR-SCHRAUBSTÖCKE
TRIPOD FOR PIPE VISE

1711



Artikel Nr. Code No.	Typ Type	A	B	C	E	H	L	d	Für Typ 1710		
									For Type 1710		kg
321711010600	1711-710	710	267	175	230	922	70	13	50; 80		14,6

- 1
- 2
- 3
- 4
- 5
- 6
- 7

- 1710
- 1711

1271

SCHWERLAST-SCHRAUBSTOCK, MULTI-AXIAL BEWEGLICH
HEAVY DUTY ALL AXIS VISE

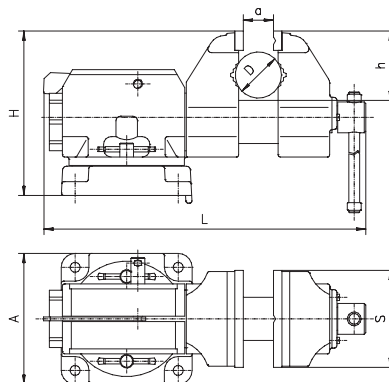
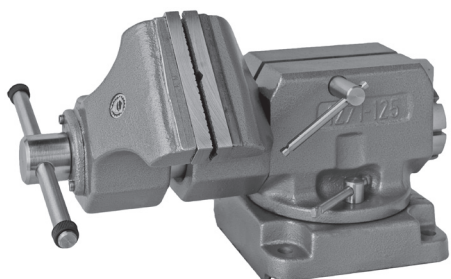

Eigenschaften:

- Mehrfachverstellbarkeit der Vertikalachse gegeben
- Aufnahme von Rundmaterial durch V-förmige Backen
- Die 360° Drehplatte ist in 45° Schritten fest arretierbar
- Induktionsgehärtete und geschliffene Stahlbacken-Einsätze, mit grobverzahnter Oberfläche
- Robuste Ausführung, Korpus aus hochwertigem Gusseisen, Backen, Basis und die restlichen Teile aus legiertem Stahl
- Komplettabdeckung der Leitspindel schützt diese vor Schmutz

Anwendung:

- Dieser hochwertige, robuste Schraubstock mit Schwalbenschwanz-Führung ist gut geeignet für besonders schweren Einsatz

Features:

- Able to rotate clamped workpiece to any angle in vertical axis and 45° pitch in horizontal axis
- Can clamp round workpieces in V-shaped jaws
- Swivel base which allow rotation through 360° with positive, firm locking in any position
- Steel jaw inserts induction hardened and ground
- Ruggedly constructed with high quality cast iron body, jaws and base with other parts made of alloy steel
- Lead-screw completely covered to keep dirt out

Application:

- This high quality, rugged vise with dovetail guides is well-suited to extra heavy work

Artikel Nr.	Typ	S	A	H	L	a max.	h	D	Max. Spannkraft [daN]	kg
Code No.	Type								Max. clamping force [daN]	
321271060700	1271-125	125	170	215	373	150	80	32-60	3.000	27,5

1
2
3
4
5
6
7

1271

Eigenschaften:

- Hohe Pressleistung
- Einfache Handhabung
- Hohe Betriebspräzision

Anwendung:

- Zum Ein- und Auspressen diverser Passelemente

Features:

- High operating precision
- High pressing force
- Simple operation

Application:

- Designed for use in any kind of pressing of various fitted elements

MANUELL BETÄTIGTE PRESSE
MANUALLY OPERATED PRESS

9210

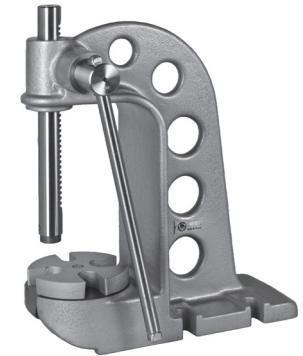
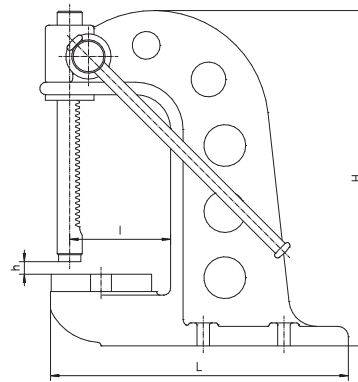

Artikel Nr.	Typ	H	h max.	L	I	Max. Spannkraft [daN]	kg
Code No.	Type					Max. clamping force [daN]	
329210110000	9210-485	485	250	420	145	2.000	39,4

- 1
- 2
- 3
- 4
- 5
- 6
- 7

9210

6582

DREHPLATTE FÜR MASCHINEN-SCHRAUBSTÖCKE
SWIVEL BASE FOR MACHINE VISES

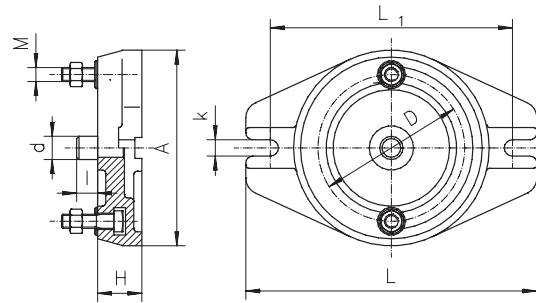
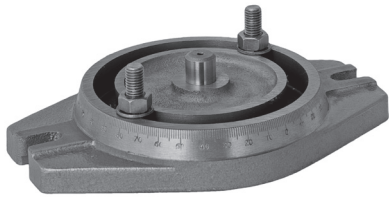

Eigenschaften:

- Robuste Gusseisen-Ausführung
- Auflagerand geschliffen
- Gradeinteilung
- Passstift aus gehärtet und geschliffenem Qualitätsstahl
- Befestigungsschrauben

Features:

- Sturdy, cast iron design
- Ground contact edge
- Graduation
- Locating pin of high quality steel, hardened and ground
- Fixing screws

Artikel Nr. Code No.	Größe Size	A	D	H	L	L1	M	d	l	k	kg	Für Typ 6512 For Type 6512
326582060900	2	168	126	45	250	208	M12	20	20	14	4,2	100, 125
326582070000	3	212	150	50	290	248	M16	20	20	18	7	160
326582080200	4	286	210	55	400	334	M16	25	25	18	14,5	200
326582090400	5	360	260	55	460	416	M16	25	25	22	27,2	250

6583

DREHPLATTE FÜR MASCHINEN-SCHRAUBSTÖCKE
SWIVEL BASE FOR MACHINE VISES

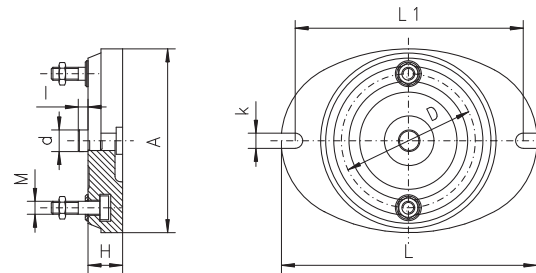
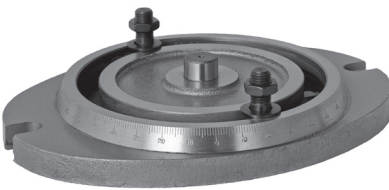

Eigenschaften:

- Robuste Gusseisen-Ausführung
- Auflagerand geschliffen
- Gradeinteilung
- Passstift aus gehärtet und geschliffenem Qualitätsstahl
- Befestigungsschrauben

Features:

- Sturdy, cast iron design
- Ground contact edge
- Graduation
- Locating pin of high quality steel, hardened and ground
- Fixing screws

Artikel Nr. Code No.	Größe Size	A	D	H	I	L	L1	M	d	k	kg	Für Typ 6910 For Type 6910
326583000600	1	170	124	32	9	237	211	M12	20	14	4,2	105
326583020000	3	245	184	38	16	328	294	M16	28	20	7,0	155
326583030100	4	300	265	47	35	405	357	M16	38	20	14,5	210

Eigenschaften:

- Robuste Gusseisen-Ausführung
- Auflagerand geschliffen
- Passstift aus gehärtet und geschliffenem Qualitätsstahl
- Befestigungsschrauben

Features:

- Sturdy cast iron design
- Ground contact edge
- Locating pin of high quality steel, hardened and ground
- Fixing screws

DREHPLATTE FÜR MASCHINEN-SCHRAUBSTÖCKE
SWIVEL BASE FOR MACHINE VISES

6585

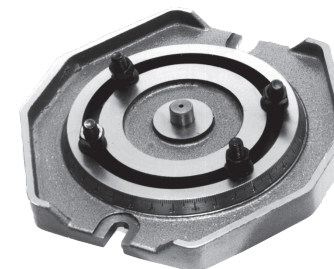
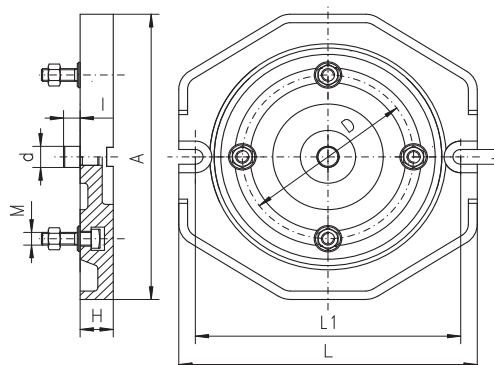

Artikel Nr. Code No.	Größe Size	A	D	H	L	L1	M	d	l	k	kg	Für Typ 6516 For Type 6516
326585060300	2	270	155	30	270	240	M12	20	20	14	8,1	125
326585070500	3	325	200	34	325	295	M12	30	20	18	16,0	160
326585080700	4	380	250	45	380	346	M16	30	20	18	27,9	200

Eigenschaften:

- Robuste Stahl-Ausführung
- Gradeinteilung

Features:

- Sturdy iron design
- Graduation

DREHPLATTE FÜR PRÄZISIONSSCHRAUBSTÖCKE
SWIVEL BASE FOR PRECISION VISES

6586

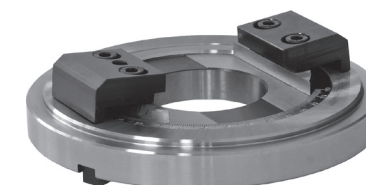
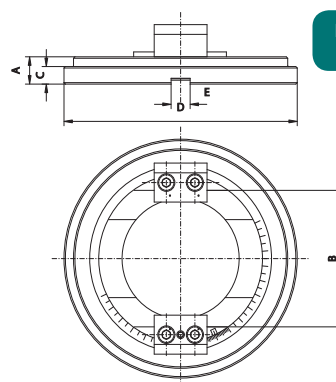

Artikel Nr. Code No.	Größe Size	A	B	D	C	E	kg	Für Typ 6577, 6578, 6620, 6621 For Type 6577, 6578, 6620, 6621
326586010200	1	23	85	190	13	12	4	100/320
326586020400	2	23	105	210	15	12	6	125/335
326586030600	3	28	140	245	18	20	9	150/425 150/475 150/520
326586040800	4	30	165	280	20	20	11	200/535 200/585 200/635

- 1
- 2
- 3
- 4
- 5
- 6
- 7

- 6585
- 6586

6587

DREHPLATTE FÜR MASCHINEN-SCHRAUBSTÖCKE
SWIVEL BASE FOR MACHINE VISES

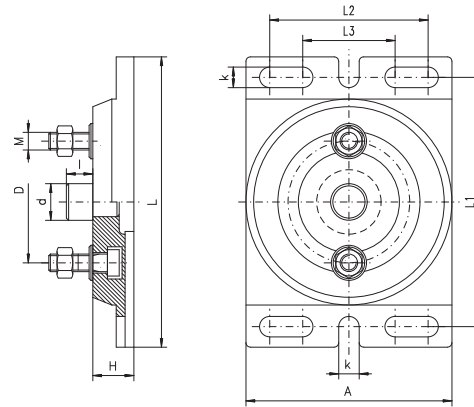
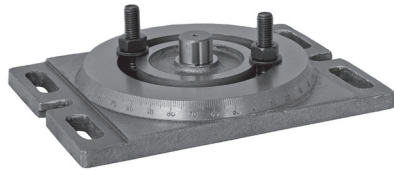

Eigenschaften:

- Robuste Gusseisen-Ausführung
- Auflagerand geschliffen
- Gradeinstellung
- Passstift aus gehärtet und geschliffenem Qualitätsstahl
- Befestigungsschrauben

Features:

- Sturdy, cast iron design
- Ground contact edge
- Graduation
- Locating pin of high quality steel, hardened and ground
- Fixing screws

Artikel Nr. Code No.	Größe Size	A	D	H	L	L1	L2	L3	M	d	l	k	kg	Für Typ 6517 For Type 6517
326587050800	1	140	83	28	198	170	108	63	M12	25	18	14	3,0	100
326587060000	2	175	103	28	236	206	126	63	M12	25	18	14	4,6	125
326587070100	3	224	130	34	294	256	184	80	M16	30	20	18	9,7	160
326587080300	4	264	165	34	345	305	220	90	M16	30	20	18	13,8	200

6588

DREHPLATTE FÜR MASCHINEN-SCHRAUBSTÖCKE
SWIVEL BASE FOR MACHINE VISES

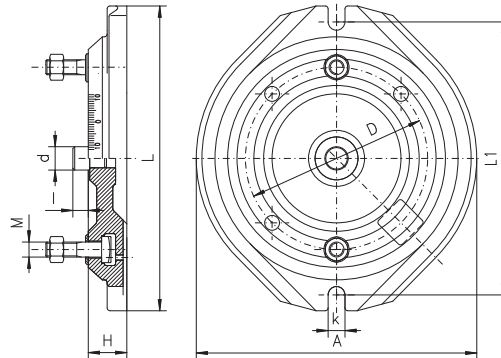

Eigenschaften:

- Robuste Gusseisen-Ausführung
- Auflagerand geschliffen
- Passstift aus gehärtet und geschliffenem Qualitätsstahl
- Befestigungsschrauben

Features:

- Sturdy cast iron design
- Ground contact edge
- Locating pin of high quality steel, hardened and ground
- Fixing screws

Artikel Nr. Code No.	Größe Size	A	D	H	L	L1	M	d	k	kg	Für Typ 6523 For Type 6523
326588030200	3	300	195	41	326	292	M16	25	18	7	155

Eigenschaften:

- Aus qualitativ hochwertigem Gusseisen gefertigt

Features:

- Made of high quality cast iron

DREHPLATTE FÜR WERKBANK-SCHRAUBSTÖCKE
SWIVEL BASE FOR HEAVY DUTY BENCH VISES

1282

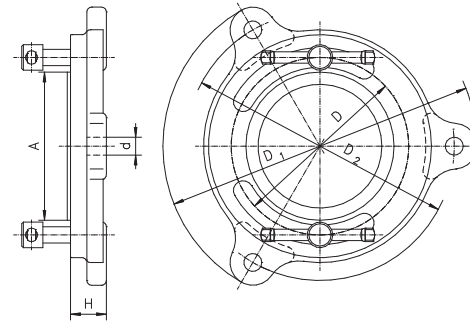

Artikel Nr. Code No.	Größe Size	A	D	D1	D2	H	d	kg	Für Typ 1250 For Type 1250
321282030700	1	78	95	168	144	19	9	0,9	63
321282040900	2	91	109	183	165	24	11	1,1	80, 100
321282050000	3	105	126	212	184	21	11	1,4	125
321282060200	4	110	134	230	200	26	13	1,8	150
321282070400	5	125	150	250	220	26	13	2,2	175

- 1
- 2
- 3
- 4
- 5
- 6
- 7

1282

GLATTE BACKEN-EINSÄTZE
PLAIN JAW INSERT

FÜR TYP • FOR TYPE
6620, 6622, 6623, 6624, 6820

Artikel Nr. Code No.	L	L1	L2	L3	L4	L5	L6	L7	L8	D	D1	D2	M
398266750500	100	23	15	32	66	9,5	7,0	-	-	6,5	10	-	M5
398266760700	125	32	18	45	80	14,0	8,5	-	-	8,0	12	-	M6
398266770900	150	42	24	67	110	18,0	11,5	-	-	10,0	15	-	M8
398266780000	200	50	30	74	140	22,0	11,5	-	-	10,0	15	-	M8

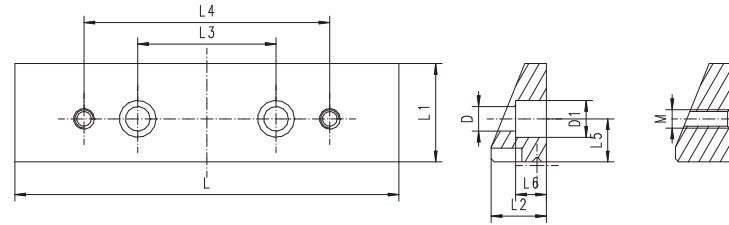

2-pc/satz • 2-pc / set

GLATTE, GESTUFTE BACKEN-EINSÄTZE
JAW INSERT WITH STEP

FÜR TYP • FOR TYPE
6620, 6622, 6623, 6624, 6820

Artikel Nr. Code No.	L	L1	L2	L3	L4	L5	L6	L7	L8	D	D1	M
398266752000	100	23	15	32	66	9,5	8,0	19	4,0	6,5	10	M5
398266762200	125	32	18	45	80	14,0	10,0	27	4,5	8,0	12	M6
398266772400	150	42	24	67	110	18,0	13,5	37	5,0	10,0	15	M8
398266782600	200	50	30	74	140	22,0	15,0	40	5,0	10,0	15	M8

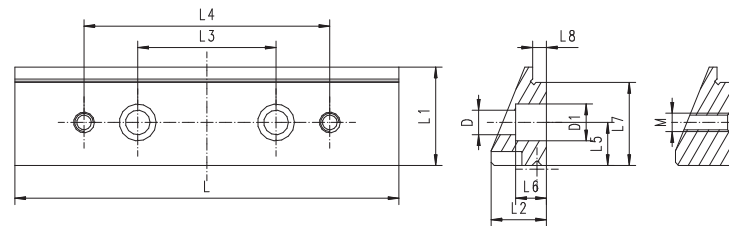

2-pc/satz • 2-pc/set

PRISMATISCHE BACKEN-EINSÄTZE
PRISMATIC JAW INSERT

FÜR TYP • FOR TYPE
6620, 6622, 6623, 6624, 6820

Artikel Nr. Code No.	L	L1	L2	L3	L4	L5	L6	L7	L8	D	D1	D2
398266756100	100	23	15	32	-	9,5	8,0	19	4,0	6,5	10	3÷20
398266766300	125	32	18	45	-	14,0	10,0	27	4,5	8,0	12	4÷27
398266776500	150	42	24	67	-	18,0	13,5	37	5,0	10,0	15	6÷41
398266786700	200	50	30	74	-	22,0	15,0	40	5,0	10,0	15	7÷48

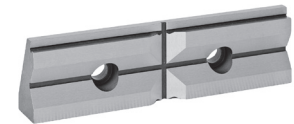
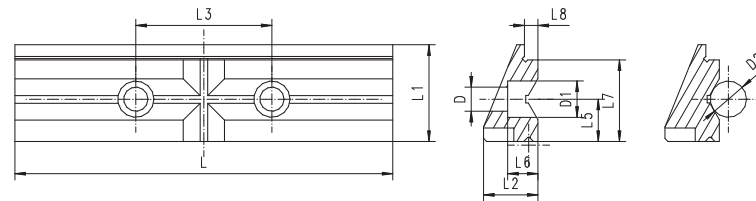

2-pc/satz • 2-pc/set

GERIFFELTE BACKEN-EINSÄTZE
GROOVED JAW INSERT

FÜR TYP • FOR TYPE
6620, 6622, 6623, 6624, 6820

Artikel Nr. Code No.	L	L1	L2	L3	L4	L5	L6	D	D1	M
398266754600	100	23	15	32	66	9,5	8,0	6,5	10	M5
398266764800	125	32	18	45	80	14,0	10,0	8,0	12	M6
398266774000	150	42	24	67	110	18,0	13,5	10,0	15	M8
398266784100	200	50	30	74	140	22,0	15,0	10,0	15	M8

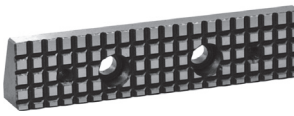
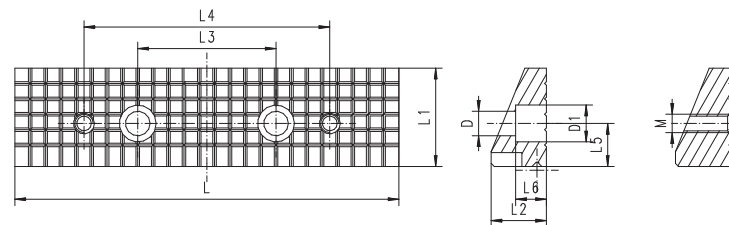

2-pc/satz • 2-pc/set

1
2
3
4
5
6
7

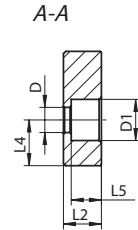
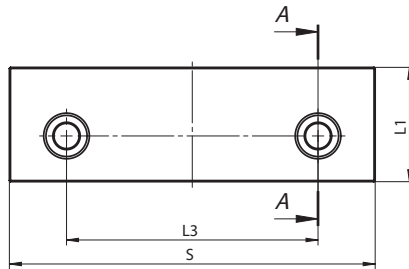

- Einseitig, glatt, gehärtet und geschliffen
- One sided, smooth, hardened and ground

SPANNBACKEN-EINSÄTZE
CLAMPING INSERTS FOR MACHINE VISES

Artikel Nr. Code No.	S	L1	L2	L3	L4	L5	D	D1	Für Typ For Type
398263110800	100	32	13,5	70	14	10,3	15	9	6512, 6530, 6537
398263120000	125	40	16,6	85	17	13,2	18	11	6512, 6530, 6531, 6537
398263130100	160	50	16,6	110	20	13,2	18	11	6512, 6515, 6516, 6522, 6530, 6531, 6537
398263140300	200	63	21,0	140	28	16,0	20	14	6512, 6515, 6516, 6522, 6531, 6537
398260595500	125	42	16,6	89	18	13,2	18	11	6515, 6516

2-pc/satz • 2-pc/set

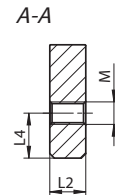
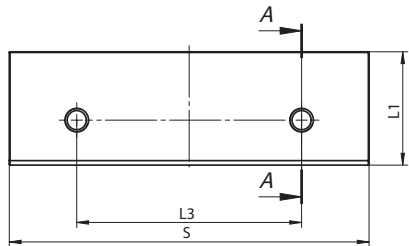

- Zweiseitig, glatt, gehärtet und geschliffen
- Two sided, smooth, hardened and ground

SPANNBACKEN-EINSÄTZE
CLAMPING INSERTS FOR MACHINE VISES

Artikel Nr. Code No.	S	L1	L2	L3	L4	M	Für Typ For Type
398263160700	100	32,4	12,5	63	14	M8	6517, 6518
398263170900	125	40,4	12,5	80	16	M10	6517, 6518
398263180000	160	50,4	16,0	100	20	M10	6517, 6518
398263190200	200	63,0	20,0	125	25	M12	6517, 6518

2-pc/satz • 2-pc/set

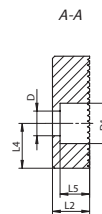
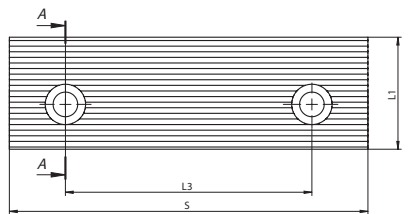

- Einseitig, 1 Seite geriffelt, 1 Seite glatt, gehärtet und geschliffen
- One sided, one side grooved, one side smooth, hardened and ground

SPANNBACKEN-EINSÄTZE
CLAMPING INSERTS FOR MACHINE VISES

Artikel Nr. Code No.	S	L1	L2	L3	L4	L5	D	D1	Für Typ For Type
398263210900	100	32	13,5	70	14	10,3	9	15	6512, 6530, 6537
398263220000	125	40	16,6	85	17	13,2	11	18	6512, 6530, 6531, 6537
398263230200	160	50	16,6	110	20	13,2	11	18	6512, 6515, 6516, 6522, 6530, 6531, 6537
398263240400	200	63	21,0	140	28	16,0	14	20	6512, 6515, 6516, 6522, 6531, 6537
398260596800	125	42	16,6	89	18	13,2	11	18	6515, 6516

2-pc/satz • 2-pc/set

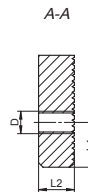
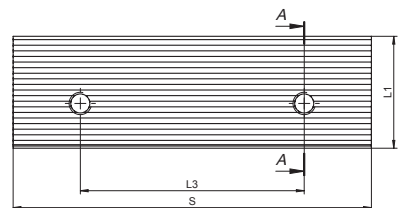
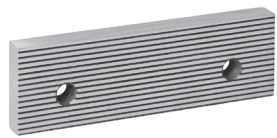

- Zweiseitig, 1 Seite geriffelt, 1 Seite glatt, gehärtet und geschliffen
- Two sided, one side grooved, one side smooth, hardened and ground

SPANNBACKEN-EINSÄTZE
CLAMPING INSERTS FOR MACHINE VISES

Artikel Nr. Code No.	S	L1	L2	L3	L4	D	Für Typ For Type
398263260800	100	32	12,5	63	14	M8	6517, 6518
398263270000	125	40	12,5	80	16	M10	6517, 6518
398263280100	160	50	16,0	100	20	M10	6517, 6518
398263290300	200	63	20,0	125	25	M12	6517, 6518

2-pc/satz • 2-pc/set

SPANNBACKEN-EINSÄTZE
CLAMPING INSERTS FOR MACHINE VISES

- Vertikale und horizontale Prismeneinsätze, gehärtet und geschliffen
- Prism inserts, for horizontal and vertical clamping of round workpieces, hardened and ground

Artikel Nr. Code No.	S	L1	L2	L3	L4	L5	D	D1	Spannbereich ø		Für Typ For Type		
									vertikal Clamping range ø vertically			horizontal Clamping range ø horizontally	
									d1	d2		d3	
398263510100	100	32,4	18	70	20	14,8	9	15,0	4-9	8-51	6-35	6512, 6530, 6537	
398263520300	125	40,0	22	85	25	18,6	11	18,0	5-12	11-71	4-45	6512, 6530, 6537	
398263530500	160	50,4	24	110	31	20,6	11	18,0	6-16	14-95	9-57	6512, 6515, 6516, 6522, 6530, 6537	
398263540700	200	63,0	30	140	40	25,0	14	20,0	7-20	18-123	12-75	6512, 6515, 6516, 6522, 6537	
398263550900	250	80,0	35	160	32	29,0	17	26,5	10-27	20-138	15-98	6512, 6537	
398260597000	125	42,0	22	89	25	18,6	11	18,0	5-12	11-71	4-45	6515, 6516	

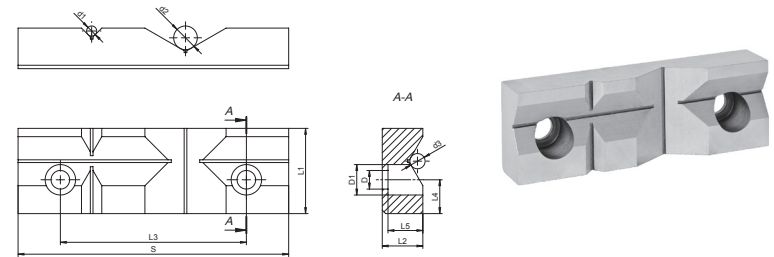

1-pc/satz • 1-pc/set

SPANNBACKEN-EINSÄTZE
CLAMPING INSERTS FOR MACHINE VISES

- Vertikale und horizontale Prismeneinsätze, gehärtet und geschliffen
- Prism inserts, for horizontal and vertical clamping of round workpieces, hardened and ground

Artikel Nr. Code No.	S	L1	L2	L3	L4	D	Spannbereich ø		Für Typ For Type		
							vertikal Clamping range ø vertically			horizontal Clamping range ø horizontally	
							d1	d2		d3	
398263590600	100	32,4	18	63	14,0	M8	4-9	8-51	6-35	6517, 6518	
398263570200	125	40,0	22	80	15,8	M10	5-12	11-71	7-45	6517, 6518	
398263580400	160	50,4	24	100	20,0	M10	6-16	14-95	9-57	6517, 6518	
398263590600	200	63,0	30	125	25,0	M12	7-20	18-123	12-77	6517, 6518	

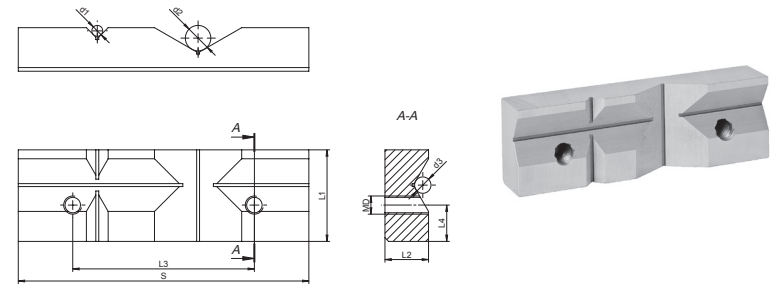

1-pc/satz • 1-pc/set

SPANNBACKEN-EINSÄTZE
CLAMPING INSERTS FOR MACHINE VISES

- Geeigte Einsätze, für das horizontale Spannen runder Werkstücke, gehärtet und geschliffen
- Inclined inserts, for horizontal clamping of round workpieces, hardened and ground

Artikel Nr. Code No.	S	L1	L2	L3	L4	L5	D	D1	Spannbereich ø	Für Typ For Type
									horizontal Clamping range ø horizontally	
398263410000	100	32,4	18	70	14	14,8	9	15	8-30	6512, 6530, 6537
398263420200	125	40,0	22	85	17	18,6	11	18	12-38	6512, 6537, 6530
398263430400	160	50,4	24	110	20	20,6	11	18	14-48	6512, 6515, 6516, 6522, 6530, 6537
398263440600	200	63,0	30	140	28	25,0	14	20	18-61	6512, 6515, 6516, 6522, 6537
398260599600	125	42,0	22	89	18	18,6	11	18	12-38	6515, 6516

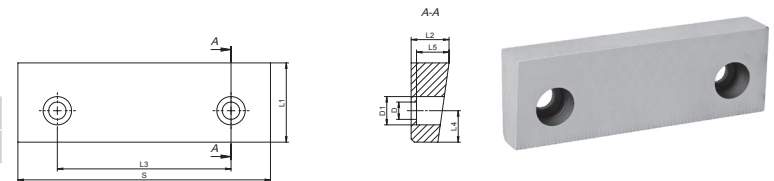

1-pc/satz • 1-pc/set

1
2
3
4
5
6
7

- Schräge Einsätze zum horizontalen Spannen runder Werkstücke, gehärtet und geschliffen
- Inclined inserts, for horizontal clamping of round workpieces, hardened and ground

SPANNBACKEN-EINSÄTZE
CLAMPING INSERTS FOR MACHINE VISES

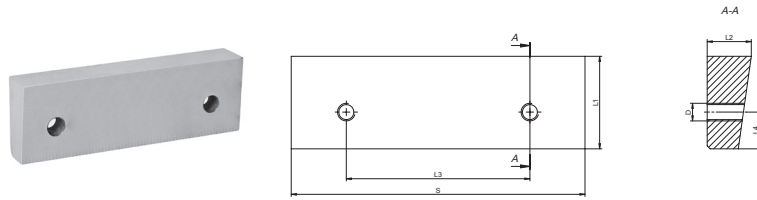

Artikel Nr.	S	L1	L2	L3	L4	D	Spannbereich ø horizontal	Für Typ
Code No.							Clamping range ø horizontally	For Type
398263460000	100	32,4	18	63	14,0	M8	8-30	6517, 6518
398263470100	125	40,0	22	80	15,8	M10	12-38	6517, 6518
398263480300	160	50,4	24	100	20,0	M10	14-48	6517, 6518
398263490500	200	63,0	30	125	25,0	M12	18-61	6517, 6518

1-pc/satz • 1-pc/set

- Vierseitige vertikale und horizontale Prismeneinsätze, mit horizontaler Vertiefung, gehärtet und geschliffen
- Four sided, prism inserts, vertical and horizontal prism, horizontal recess, hardened and ground

SPANNBACKEN-EINSÄTZE
CLAMPING INSERTS FOR MACHINE VISES

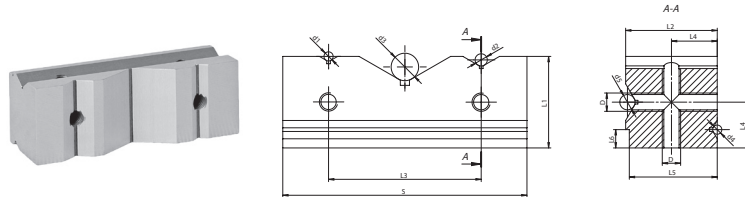

Artikel Nr.	S	L1	L2	L3	L4	L5	L6	D	Spannbereich ø vertikal			Spannbereich ø horizontal		Für Typ
									Clamping range ø vertically			Clamping range ø horizontally		
Code No.									d1	d2	d3	d4	d5	For Type
398261360200	80	30	30	50	15	28,8	6	M6	3-11	4-23	9-59	3-11	4-23	6542
398261370400	100	35	35	60	17,5	33,0	6	M8	3-15	5-27	11-69	3-15	5-27	6542

1-pc/satz • 1-pc/set

- Zweifach vertikal- prismatische Einsätze
- Prism inserts. Two vertical prism for clamping of round workpieces

SPANNBACKEN-EINSÄTZE
CLAMPING INSERTS FOR MACHINE VISES

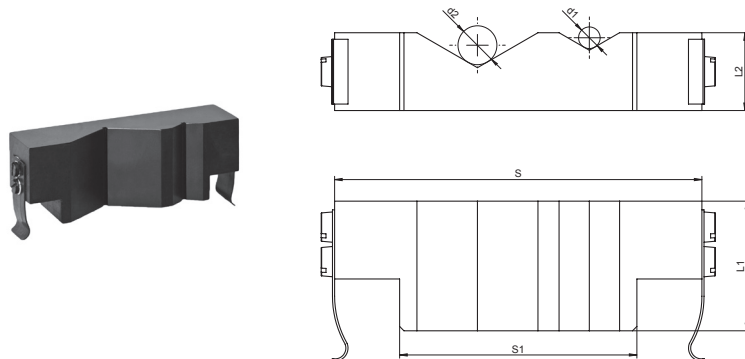

Artikel Nr.	Größe	S	S1	L1	L2	Spannbereich ø vertikal		Für Typ
						Clamping range ø vertically		
Code No.	Size					d1	d2	For Type
398262450000	80	70	45,9	26	16	4-18	8-45	6540
398262460100	100	85	54,9	30	18	5-25	9-55	6540
398262470300	125	105	74,9	38	25	6-28	14-90	6540
398262480500	160	138	101,9	44	33	7-38	20-135	6540

1-pc/satz • 1-pc/set

SPANNBACKEN-EINSÄTZE
CLAMPING INSERTS FOR MACHINE VISES

- Vertikale und horizontale Prismeneinsätze mit Spannstufe, gehärtet und geschliffen
- Prism inserts, vertical and horizontal prism, longitudinal recess, hardened and ground



Artikel Nr. Code No.	S	L1	L2	L3	L4	L5	L6	L7	L8	L9	L10	D	D1	Spannbereich ø vertikal	Spannbereich ø horizontal	Für Typ
														Clamping range ø vertically d1	Clamping range ø horizontally d2	For Type
398263310000	100	32,4	18	70	14	14,8	26	4	13,5	10,3	4,0	9	15	8-50	6-24	6512, 6537, 6530
398263320100	125	40,0	22	85	17	18,6	32	4	16,0	12,6	4,0	11	18	11-70	8-30	6512, 6537, 6530
398263330300	160	50,4	24	110	20	20,6	42	4	16,6	13,0	4,6	11	18	14-95	9-35	6512,6537 6515,6516 6530
398263340500	200	63,0	30	140	28	25,0	55	4	21,0	16,0	4,0	14	20	18-123	12-44	6512,6537 6515,6516 6522
398260598300	125	42,0	22	89	18	18,6	34	4	16,0	12,6	4,0	11	18	11-70	8-30	6515,6516

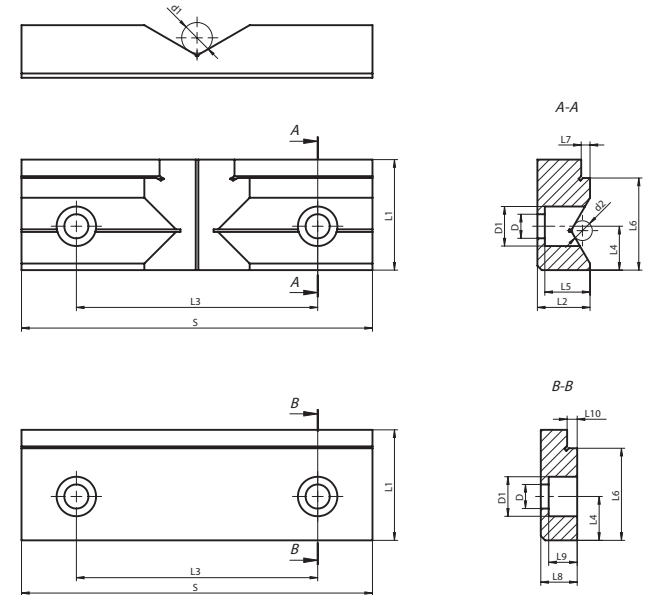

2-pc/satz • 2-pc/set

SPANNBACKEN-EINSÄTZE
CLAMPING INSERTS FOR MACHINE VISES

- Vertikale und horizontale Prismeneinsätze mit Spannstufe, gehärtet und geschliffen
- Prism inserts, vertical and horizontal prism, longitudinal recess, hardened and ground



Artikel Nr. Code No.	S	L1	L2	L3	L4	L6	L7	L8	L9	D	Spannbereich ø vertikal	Spannbereich ø horizontal	Für Typ
											Clamping range ø vertically d1	Clamping range ø horizontally d2	For Type
398263360900	100	32,4	18	63	14,0	26	4	13,5	4,0	M8	8-50	6-24	6517, 6518
398263370000	125	40,0	22	80	15,8	32	4	16,0	4,0	M10	11-70	8-30	6517, 6518
398263380200	160	50,4	24	100	20,0	42	4	16,6	4,6	M12	14-95	9-35	6517, 6518
398263390400	200	63,0	30	125	25,0	55	4	21,0	4,0	M12	18-123	12-44	6517, 6518

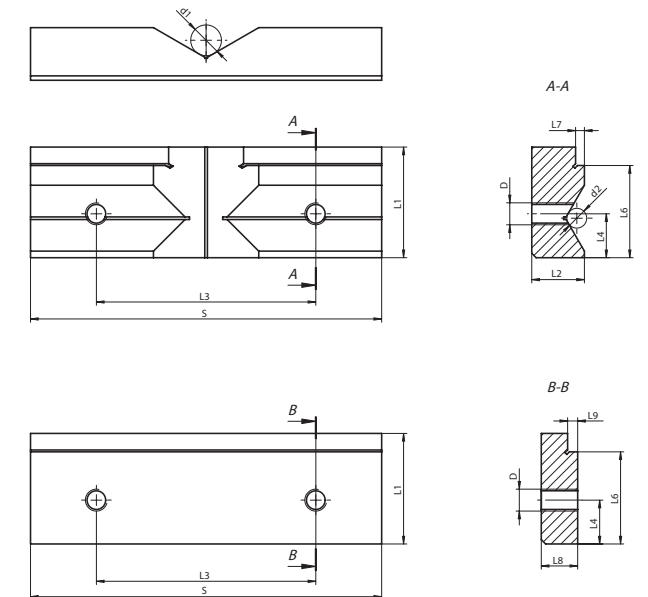

2-pc/satz • 2-pc/set

- 1
- 2
- 3
- 4
- 5
- 6
- 7

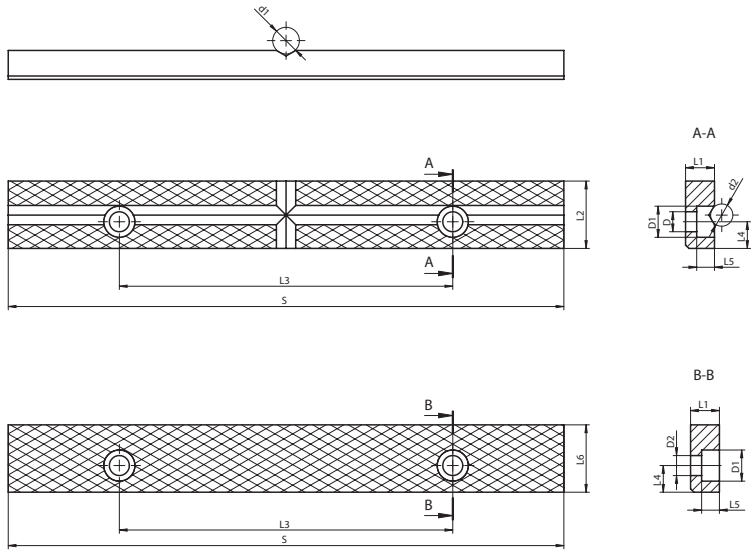

2-pc/satz • 2-pc/set

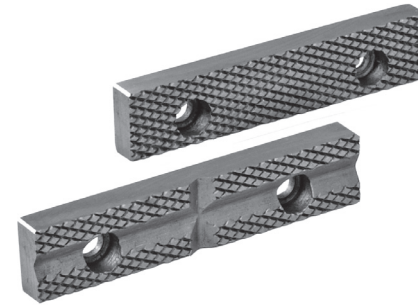

SPANNBACKEN-EINSÄTZE
CLAMPING INSERTS FOR BENCH VISES

Artikel Nr. Code No.	S	L1	L2	L3	L4	L5	L6	D	D1	D2	Spannbereich ø vertikal	Spannbereich ø horizontal	Für Typ
											Clamping range ø vertically d1	Clamping range ø horizontally d2	For Type
398210520200	80	9	20,7	50	8	6,0	20,4	7	11	6,6	3-13	3-13	1240, 1250
398210522800	100	9	20,7	60	8	6,0	20,4	7	11	6,6	3-13	3-13	1240, 1250
398210525600	125	9	21,5	60	8	6,5	21,5	7	11	7,0	4-16	3-13	1240, 1250
398210530400	150	11	25,2	100	10	8,0	25,2	9	14	9,0	4-16	4-16	1240, 1250
398210533200	175	13	30,3	100	12	8,0	30,3	9	14	9,0	4-16	4-16	1250
398210550800	175	11	25,2	10	10	8,0	25,2	9	14	9,0	4-16	4-16	1240
398210552300	200	13	30,3	150	12	8,0	30,3	9	14	9,0	4-16	4-16	1240
398210555100	250	13	30,3	150	12	8,0	30,3	9	14	9,0	4-16	4-16	1240

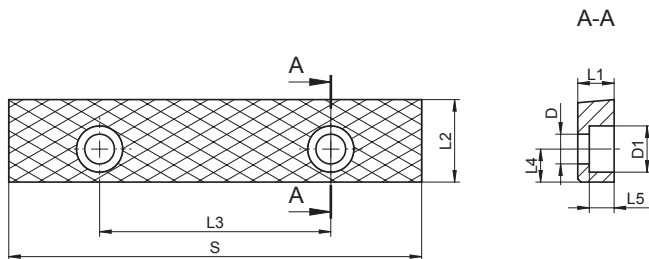

1-pc/satz • 1-pc/set

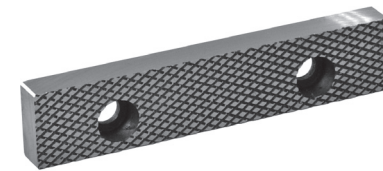

SPANNBACKEN-EINSÄTZE
CLAMPING INSERTS FOR BENCH VISES

Artikel Nr. Code No.	S	L1	L2	L3	L4	L5	D	D1	Für Typ For Type
398210200600	63	7	17,4	40	7,5	5,6	6	9,5	1250, 1256
398210984800	125	11	25,0	70	10,0	7,5	9	14,0	1271

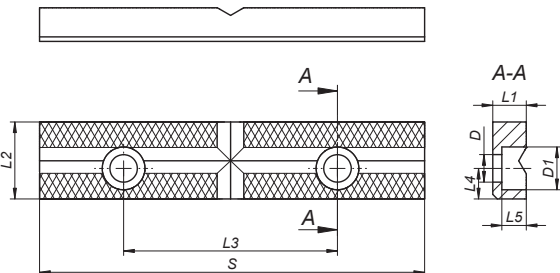

1-pc/satz • 1-pc/set



SPANNBACKEN-EINSÄTZE
CLAMPING INSERTS FOR BENCH VISES

Artikel Nr. Code No.	S	L1	L2	L3	L4	L5	D	D1	Für Typ For Type
398210994000	126	11	25,2	70	10	8	9	14,0	1271

1
2
3
4
5
6
7

HANDKURBELN FÜR MASCHINENSCHRAUBSTÖCKE
HANDCRANK FOR MACHINE VISES

Artikel Nr. Code No.	Vierkant x Länge Square x Length	Für Typ For Type
398260851000	12 x 160	6517,18-100
398260861100	14 x 160	6517,18-125, 6531-125, 6546-125, 6531-160, 6524-125
398267410300	17 x 160	6910,11-105, 6910,11-155, 6910,11-155S, 6910,11-210



HANDKURBELN FÜR MASCHINENSCHRAUBSTÖCKE
HANDCRANK FOR MACHINE VISES

Artikel Nr. Code No.	Vierkant x Länge Square x Length	Für Typ For Type
398261110100	17 x 200	6512,37-100,125,160,200, 6530-100,125,160, 6522-160,200, 6517,18-160,200, 6546-160, 6531-200
398260880200	19 x 200	6512,37-250



HANDKURBELN FÜR MASCHINENSCHRAUBSTÖCKE
HANDCRANK FOR MACHINE VISES

Artikel Nr. Code No.	Vierkant x Länge Square x Length	Für Typ For Type
398261091800	11 x 180	6546-100



HANDKURBELN FÜR MASCHINENSCHRAUBSTÖCKE
HANDCRANK FOR MACHINE VISES

Artikel Nr. Code No.	Sechskant x Länge Hex x Length	Für Typ For Type
398263900300	12 x 200	6515,16-125 6515,16-160 6515,16-200



HANDKURBELN FÜR MASCHINENSCHRAUBSTÖCKE
HANDCRANK FOR MACHINE VISES

Artikel Nr. Code No.	Sechskant x Länge Hex x Length	Für Typ For Type
398261125700	19x228	6523-155



GEBOGENE STECKSCHLÜSSEL
ANGLE SOCKET WRENCH

Artikel Nr. Code No.	Größe Size	Für Typ For (150, 200)
398263800200	100,125	6568, 6620,
398263810400	150, 200	6622, 6820



HYDRAULIKSPINDEL
HYDRAULIC SPINDLE

Artikel Nr. Code No.	Größe Size	Für 6515, 6516 For 6515, 6516	A	B	C	D	E	L	3690-M	
									Max. Spannkraft [daN] Max. clamping force [daN]	kg
323690220400	2	125	Tr 28 x 5	14	50	215	392	408	3.500-4.000	3,0
323690240800	3	160	Tr 32 x 6	16	58	230	465	485	5.500-6.000	4,5
323690250000	4	200	Tr 36 x 6	18	64	273	608	619	7.500-8.000	6,8

Artikel Nr. Code No.	Größe Size	Für 6621, 6821 For 6621, 6821	A	B	C	D	L	3690-MN	
								Max. Spannkraft [daN] Max. clamping force [daN]	kg
323690121600	2	150	Tr28 x 5	110	50	215	370	3.500-4.000	2,4
323690131800	3	200	Tr32 x 6	117	58	230	403	5.500-6.000	3,8

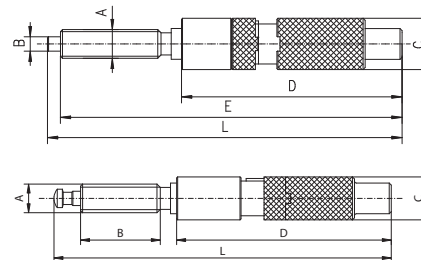

- Der Aufbau dieser der hydraulischen Spindel, mit mechanischer Kupplung, bietet die Auswahl zwischen rein mechanischem oder hydraulischem Einsatz
- Die rein mechanische Anwendung wird speziell bei Werkstücken aus weichen Materialien empfohlen, welche unter dem hydraulischen Druck verformt werden können.
- Robuste Ausführung
- The hydraulic spindle is equipped with a mechanical clutch which makes it possible to choose the type of operation - mechanical only or using the hydraulic system
- Mechanical clamping is especially required when the clamped object is made of deformable materials which could be damaged when clamped with the hydraulic system
- Sturdy design

- Optionales Zubehör in Verbindung mit Typen 6620-6624, 6820 und 6821
- Optional accessories used with vises 6620-6624, 6820 and 6821

LEITSPINDEL
LEAD SCREW

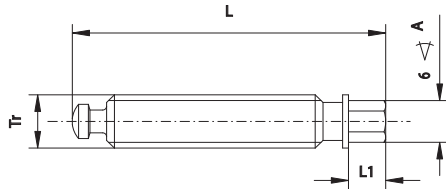

Artikel Nr. Code No.	Größe Size	L	L1	A	Tr
398263910500	100	120	18	13	Tr18x4
398263920700	125	125	18	13	Tr18x4
398263931100	150	160	19	19	Tr28x5
398263941300	200	170	19	19	Tr32x6

- Optionales Zubehör in Verbindung mit Typen 6620-6624, 6820 und 6821
- Optional accessories used with vises 6620-6624, 6820 and 6821

BLOCK
BLOCK

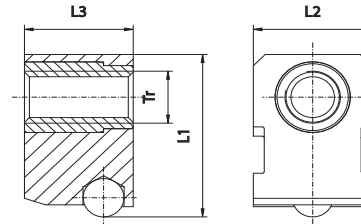

Artikel Nr. Code No.	Größe Size	L1	L2	L3	Tr
398266510600	100	55,5	35,0	36	Tr18x4
398266520800	125	68,5	40,5	40	Tr18x4
398266530000	150	87,5	60,0	55	Tr28x5
398266540100	200	104,5	70,0	65	Tr32x6

- Optionales Zubehör in Verbindung mit Typen 6620-6624, 6820 und 6821
- Optional accessories used with vises 6620-6624, 6820 and 6821

LEITSPINDEL MIT BLOCK
LEAD SCREW WITH BLOCK

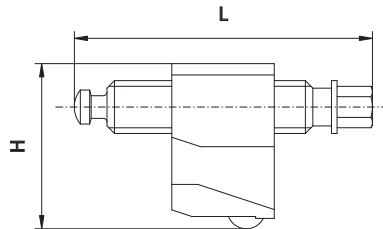

Artikel Nr. Code No.	Größe Size	L	H
398266550300	100	120	55,5
398266560500	125	125	68,5
398266570700	150	160	87,5
398266580900	200	170	104,5

- Optionales Zubehör in Verbindung mit Typen 6620-6624, 6820 und 6821
- Optional accessories used with vises 6620-6624, 6820 and 6821

HALTERUNG
CLAMP

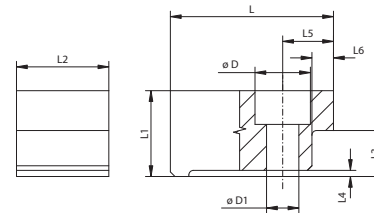

Artikel Nr. Code No.	Größe Size	L	L1	L2	L3	L4	L5	L6	D	D1
398266710800	100	50	24	30	13	2	13,5	6,5	18	10,5
398266720000	125	53	28	30	15	2	16,6	7,0	18	10,5
398266730100	150	75	35	42	18	2	37,0	8,0	26	17,0
398266740300	200	91	39	42	20	2	24,5	8,0	26	17,0

HALTERUNG FÜR PRÄZISIONSSCHRAUBSTÖCKE 6586
CLAMP FOR 6586

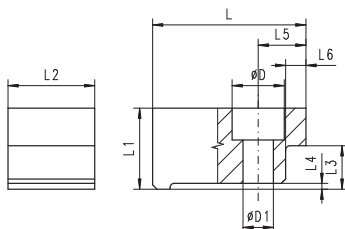
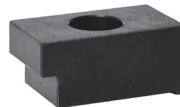

Artikel Nr. Code No.	Größe Size	L	L1	L2	L3	L4	L5	L6	D	D1
398263650000	1	58	22,5	28	13	2	20	8	20	13
398263660100	2	62	22,5	28	15	2	20	8	20	13
398263670300	3	70	27,5	32	18	2	23	8	22	15
398263680500	4	80	29,5	35	20	2	23	8	22	15

SEITLICHER ANSCHLAG
SIDE STOP

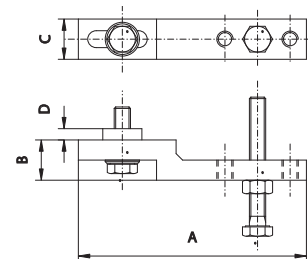

Artikel Nr. Code No.	Größe Size	A	B	C	D	Für Typ For Type
326597010800	100,125	120	20	20	5	6577, 6578, 6569-M, 6620,
326597020000	150,200	140	25	25	7	6621, 6624, 6820, 6821

1
2
3
4
5
6
7

NUTENSTEINE (B)
SLOT NUTS (B)

12/14; 12/16; 12/18;
18/20; 18/22

12/12; 18/18; 20/20

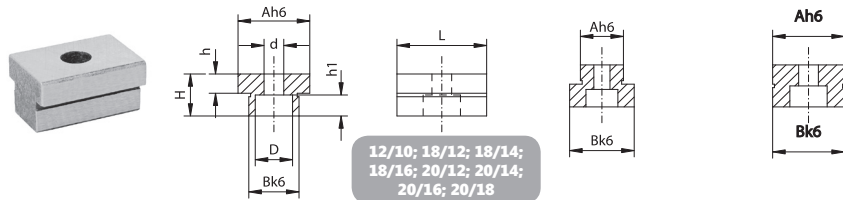

12/10; 18/12; 18/14;
18/16; 20/12; 20/14;
20/16; 20/18

Artikel Nr. Code No.	Größe Size	A	B	L	H	h	h1	D	d
398263750000	12/10	12	10	20	12	3,5	5,7	8,9	5,5
398263752600	12/12	12	12	20	12	3,5	5,7	8,9	5,5
398263754100	12/14	12	14	20	12	3,5	5,7	8,9	5,5
398263756700	12/16	12	16	20	12	3,5	5,7	8,9	5,5
398263757000	12/18	12	18	20	12	3,5	5,7	8,9	5,5
398263759500	12/20	12	20	20	12	3,5	5,7	8,9	5,5
398266810900	18/12	18	12	25	12	4,5	6,8	10,4	6,6
398266812400	18/14	18	14	25	12	4,5	6,8	10,4	6,6
398266814000	18/16	18	16	25	12	4,5	6,8	10,4	6,6
398266816500	18/18	18	18	25	12	4,5	6,8	10,4	6,6
398266818000	18/20	18	20	25	12	4,5	6,8	10,4	6,6
398266820000	18/22	18	22	25	12	4,5	6,8	10,4	6,6
398263758200	20/12	20	12	25	12	4,5	6,8	10,4	6,6
398263760200	20/14	20	14	25	12	4,5	6,8	10,4	6,6
398263762800	20/16	20	16	25	12	4,5	6,8	10,4	6,6
398263764300	20/18	20	18	25	12	4,5	6,8	10,4	6,6
398263766900	20/20	20	20	25	12	4,5	6,8	10,4	6,6

KUPPLUNGEN
COUPLERS

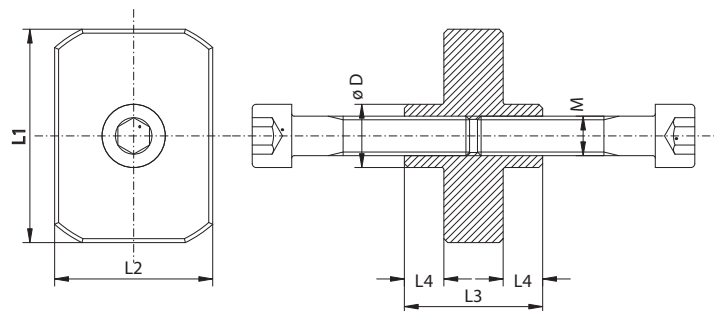

Kupplungen Coupler	L1	L2	L3	L4	D	M
M10x35	46	35	35	10	16	M10x35-10,9
M10x85	46	35	35	10	16	M10x85-10,9
M10x45	54	40	35	10	16	M10x45-10,9
M10x105	54	40	35	10	16	M10x105-10,9
M12x55	62	40	43	12	18	M12x55-10,9
M12x130	62	40	43	12	18	M12x130-10,9

Abb.1 Fig.1



Abb.2 Fig.2



Für Typ For Type	Abb. 1 • Fig. 1		Abb. 2 • Fig. 2	
	Kupplungen Coupler	Artikel Nr. Code No.	Kupplungen Coupler	Artikel Nr. Code No.
6820-100-320/160	M10x35	398267220300	M10x85	398267221600
6820-125-335/160	M10x45	398267222900	M10x105	398267223100
6820-150-425/205	M12x55	398267224400	M12x130	398267225700

1
2
3
4
5
6
7

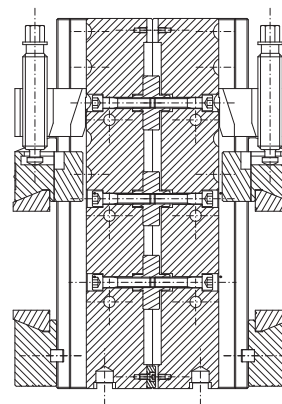
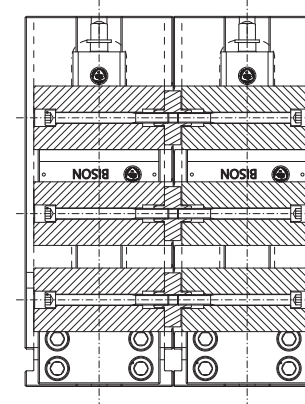
WERKZEUGMACHER UND PRÜFSCHRAUBSTÖCKE
TOOLMAKER'S AND INSPECTION VISES

Typ Type	a	b	c
6552-63	0,005	0,003	0,005
6552-80	0,005	0,003	0,005
6552-100	0,007	0,005	0,005
6553-63	0,005	0,003	0,005
6553-80	0,005	0,003	0,005
6553-100	0,007	0,005	0,005
6554-63	0,005	0,003	0,005
6554-80	0,005	0,003	0,005
6554-100	0,007	0,005	0,005
6555-80	0,005	0,003	0,005

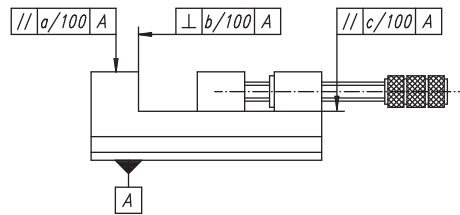

- Für unebene Werkstücke kann eine geführte bewegliche Platte verwendet werden, deren Backen-Schwenkbereich ca. $\pm 3^\circ$ beträgt
- Ein seitlicher Anschlag an der fixen Backe ermöglicht eine Werkstückaufnahme parallel zur Backenoberfläche
- For clamping the workpieces of irregular shape a swinging leading plate can be used which allows for swiveling of movable jaw by about $\pm 3^\circ$ angle.
- Side stop (Type 6597) screwed to fixed jaw side enables positioning the workpieces parallel to jaw inserts surface

GEBRAUCH DES SEITLICHEN ANSCHLAGES TYP 6597
USAGE OF SIDE STOP TYPE 6597

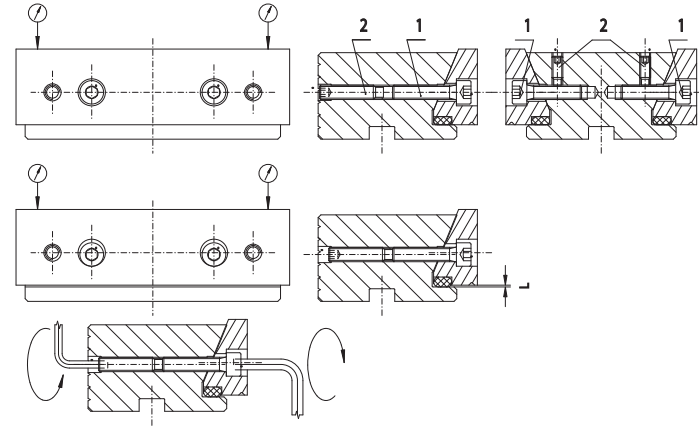
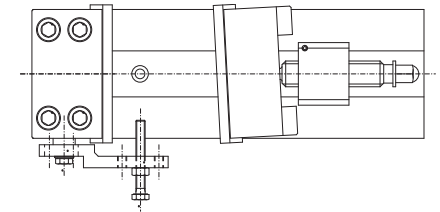

JUSTIERUNG DER BACKENEINSÄTZE
ADJUSTING THE POSITION OF JAW INSERTS

- Das korrekte Spannen des Werkstückes wird nur dann erreicht, wenn die Backeneinsätze auf ihren Führungen sitzen. Nur so kann die Genauigkeit der Werkstückspannung sichergestellt werden.
- Proper clamping of the workpiece will be obtained when jaw inserts are seated on the jaw guides. Only then the proper accuracy of the workpiece fixing will be ensured.

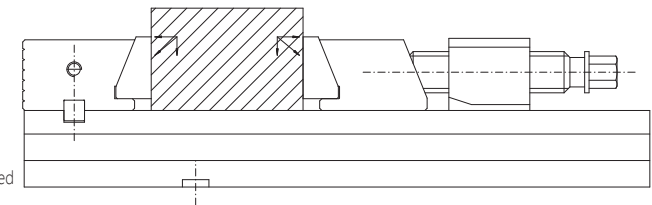

- Einstellbare Backeneinsätze gewährleisten korrekten Werkstückhalt
- Der Einstellbereich „L“ beträgt 0,2 mm mit einer Positioniergenauigkeit von $\pm 0.01\text{mm}$
- Der Unterschied des „L“- Maßes beider Backen sollte 0.01mm nicht übersteigen
- Zur Positionierung des festklemmenden Einsatzes ist wie folgt vorzugehen:
 - 1 - Lösen der Klemmschrauben (2)
 - 2 - Verstellen der Backeneinsätze in ihrer Führung mittels der Schraubbolzen (1)
 - 3 - Überprüfen der Parallelität des Backeneinsatzes zur Schraubstockunterseite
 - 4 - Einstellen des erforderlichen Werts $L = 0,2 (\pm 0,01 \text{ mm})$ durch Betätigen der Bolzen (1)
 - 5 - Erneute Überprüfung der Parallelität gemäß Punkt 3, das vorherige Ergebnis muss sich dabei bestätigen
 - 6 - Sichern der Bolzen (1) durch Festziehen der Klemmschrauben (2)
- Vollziehen Sie bitte die Einstellung der Einsätze, in beweglicher und fixer Backe, entsprechend dem beschriebenen Ablaufs

- Clamping inserts in the vise jaws have preset play, ensuring that workpieces are correctly clamped
- The amount of this play should be $L = 0,2 \text{ mm}$ with positioning accuracy of $\pm 0.01\text{mm}$
- The difference between "L" dimensions in movable and fixed jaws should not exceed 0,01mm
- To obtain the required positioning of the clamping insert proceed as follows:
 - 1 - loosen set screws (2)
 - 2 - tighten the bolts (1) to make the clamping insert sit in the jaw guide
 - 3 - use the dial gauge to check the parallelism of the clamping insert to the vise base
 - 4 - set the required value of $L = 0,2 (\pm 0,01 \text{ mm})$ by loosening the bolts (1)
 - 5 - use the dial gauge to check the parallelism of the clamping insert to the vise base, the parallelism of the clamping insert to the vise base should be the same as measured in point 3
 - 6 - secure bolts (1) by tightening set screws (2)
- Perform above steps for setting clamping inserts both in fixed and movable jaws

- 1
- 2
- 3
- 4
- 5
- 6
- 7

ANWENDUNGSBEISPIELE FÜR MODULAR - SCHRAUBSTÖCKE
EXAMPLE OF USING MODULE VISE

